

Indigo™ Series 500 Ice Cube Machine

Model: IR-0500A ID-0502A IY-0504A IR-0501W ID-0503W IY-0505W
 ID-0592N IY-0594N



Indigo Series i-500
Ice Machine on B-570 Bin

Designed for operators who know that ice is critical to their business, the Indigo™ Series ice machine's preventative diagnostics continually monitor itself for reliable ice production. Improvements in cleanability and programmability make your ice machine easy to own and less expensive to operate.

- **Space-Saving Design** – Up to 560 lbs. (254 kgs.) daily ice production and only 30" (76.20 cm) wide.
- **Intelligent Diagnostics** – provide 24 hour preventative maintenance and diagnostic feedback for trouble free operation.
- **Acoustical Ice Sensing Probe** – for reliable operation in challenging water conditions.
- **EasyRead Display** – communicates operating status, cleaning reminders, and asset information through a blue illuminated display.
- **Programmable Ice Production** – by On/Off Time, Ice Volume or Bin Level (with accessory bin level control) further improves energy efficiency and savings.
- **Easy to Clean Foodzone** – Hinged front door swings out for easy access. Removable water-trough, distribution tube, curtain, and sensing probes for fast and efficient cleaning. Select components made with AlphaSan® antimicrobial.
- **DuraTech™ Exterior** – provides superior corrosion resistance. Stainless finish with innovative clear-coat resists fingerprints and dirt.
- Available **LuminIce™ Growth Inhibitor** controls the growth of bacteria and yeast within the foodzone.

Specifications

BTU Per Hour:
6,100 (average) 6,900 (peak)

Refrigerant:
R-404A CFC-free

Operating Limits:

- Ambient Temperature Range: 35° to 110°F (1.7° to 43.3°C)
- Water Temperature Range: 35° to 90°F (1.7° to 32.2°C)

- Water Pressure Ice Maker Water In:
Min. 20 psi (137.9 kPa)
Max. 80 psi (551.1 kPa)

Ice Machine Electric

115/60/1 standard.
(208-230/60/1 and 230/50/1 also available)

Minimum circuit ampacity:

Air cooled: 14.2
Water Cooled: 13.5
Remote: 20.0

Maximum fuse size:

Air Cooled: 20.0
Water Cooled: 20.0
Remote: 25.0



Ice Shape

Half Dice
3/8" x 1 1/8" x 7/8"
(.95 x 2.86 x 2.22 cm)

Dice
7/8" x 7/8" x 7/8"
(2.22 x 2.22 x 2.22 cm)

Regular
1 1/8" x 1 1/8" x 7/8"
(2.86 x 2.86 x 2.22 cm)



2110 South 26th Street
PO Box 1720
Manitowoc, WI 54221-1720 USA

Tel: 1.920.682.0161
Fax: 1.920.683.7589

www.manitowocice.com





i-500 on B-570 Storage Bin

- (A) Electrical Entrance (2) Options
- (B) 3/8" (0.95 cm) F.P.T. Water Condenser Inlet (water-cooled units)
- (C) 1/2" (1.27 cm) F.P.T. Water Condenser Outlet (water-cooled units)
- (D) 1/2" (1.27 cm) Auxiliary Base Drain Socket
- (E) 3/8" (0.95 cm) F.P.T. Ice Making Water Inlet
- (F) 1/2" (1.27 cm) F.P.T. Ice Making Water Drain
- (G) 3/4" (1.91 cm) Bin Drain

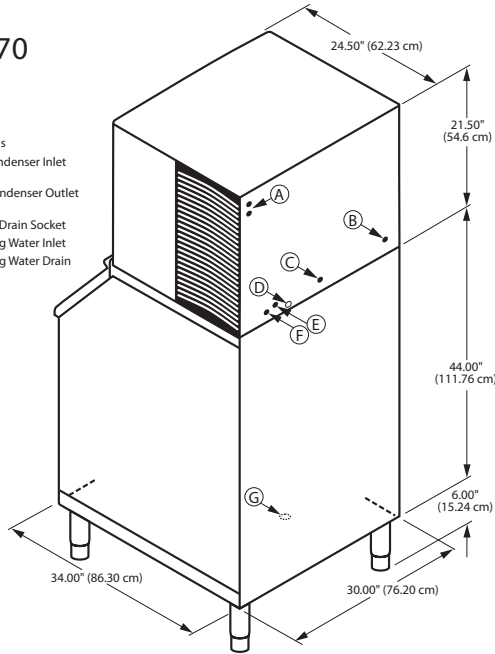

Installation Note
Minimum installation clearance:
Top/sides: 8" (20.32 cm);
Back is 5" (12.7 cm)

Space-Saving Designs



	i-500 B-400	i-500 B-570
Height	59.50" 151.13 cm	71.50" 181.61 cm
Width	30.00" 76.20 cm	30.00" 76.20 cm
Depth	34.00" 86.30 cm	34.00" 86.30 cm
Bin Storage	290 lbs. 131.54 kgs.	430 lbs. 195.04 kgs.

Height includes adjustable bin legs 6.00" to 8.00", (15.24 to 20.32 cm) set at 6.00" (15.24 cm).

Specifications

Model	Ice Shape	Ice Production 24 Hours		Power Usage kWh/100 lbs. @ 90°Air/70°F	Water Usage/100 lbs. 45.4 kgs. of Ice	ENERGY STAR®
		70°Air/50°F Water	90°Air/70°F Water			
AIR-COOLED	IR-0500A regular	500 lbs.	370 lbs.	5.94	19.9 Gal. 75.3 L	★
		227 kgs.	168 kgs.			
	ID-0502A dice	530 lbs. 240 kgs.	390 lbs. 177 kgs.	5.79	19.9 Gal. 75.3 L	★
IY-0504A half-dice	560 lbs. 254 kgs.	410 lbs. 186 kgs.	5.73	19.9 Gal. 75.3 L	★	
WATER-COOLED	IR-0501W regular	500 lbs.	420 lbs.	4.58	19.9 Gal. 75.3 L	NA
		227 kgs.	191 kgs.			
	ID-0503W dice	550 lbs. 249 kgs.	430 lbs. 195 kgs.	4.58	19.9 Gal. 75.3 L	NA
IY-0505W half-dice	550 lbs. 249 kgs.	440 lbs. 200 kgs.	4.52	19.9 Gal. 75.3 L	NA	
* Water-cooled Condenser Water Usage / 100 lbs. /45.4 kgs. of Ice: 165 gal/625 L * Water-cooled models are excluded from ENERGY STAR qualification.						
REMOTE-COOLED	ID-0592N dice	480 lbs.	430 lbs.	5.79	19.9 Gal. 75.3 L	★
		218 kgs.	195 kgs.			
IY-0594N half-dice	510 lbs. 231 kgs.	440 lbs. 200 kgs.	5.73	19.9 Gal. 75.3 L	★	

Order ice storage bin separately. Ice storage bin and JC-0495 remote condenser must be ordered separately. Consult remote condenser specification sheet for details.

Accessories

LuminIce™ Growth Inhibitor
reduces yeast and bacteria growth for a cleaner ice machine.



Bin Level Control
Allows ice bin level to be automatically set. Built-in LED light illuminates bin.



Arctic Pure® Water Filters
Reduces sediment and chlorine odors for better tasting ice.



AuCS®
schedules and performs routine ice machine cleaning automatically.





LuminIce™ Growth Inhibitor

Model

Factory Built-in Option
(Add "X" to end of Indigo model number)

K-00424 Upgrade Kit
(for Indigo: i-300 to i-1200 and QuietQube i-680C to i-1070C)

K-00434 Upgrade Kit
(for Indigo: i-1400 & i-1800, IB Series, and QuietQube i-1470C to i-2170C)

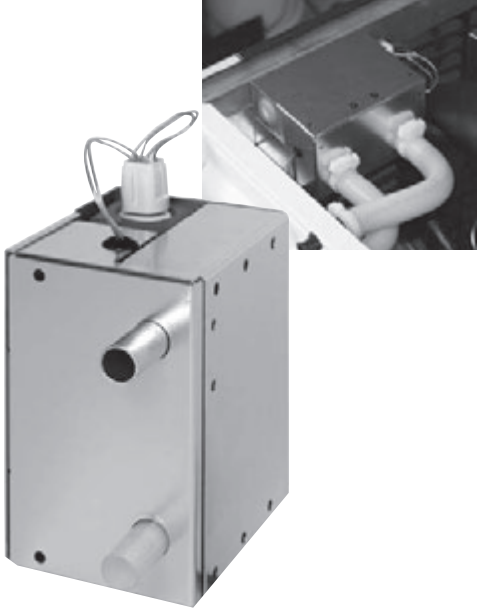

Standard Features

- **Reduced Yeast and Bacteria Growth** – proven by independent lab testing to inhibit the growth of yeast and bacteria for a cleaner foodzone.
- **Easier Cleaning** – reduced slime build up speeds the regularly scheduled cleaning process.
- **Space Saving Design** - device mounts inside the Indigo Series ice machine preserving space clearances in tight areas.
- **Easy to Use** - no chemicals to add or maintain. Only a simple UV bulb change is recommended once a year to maintain effectiveness. *Note: bulb change reminders can be programmed into the Indigo display.*

Warranty

- 3-year warranty covering all parts and labor from the date of original installation (UV bulb is excluded from this warranty).
- UV Bulb replacement part warranty 90 days.

The LuminIce Growth Inhibitor creates "active air" by recirculating the air inside the ice machine food zone over a UV light. This "active air" passes over exposed food zone components to inhibit the growth of yeast, bacteria, and other common microorganisms.

Foodservice operations can often be in challenging environments where it is difficult to prevent yeast, mold and other micro-organism contamination. With LuminIce, testing has shown that ice machine foodzones are noticeably cleaner after only 2-1/2 months of usage.



The LuminIce device runs quietly 24 hours a day keeping your ice machine cleaner and helping to relieve the stress and pain of frequent cleanings. Reduced cleanings ultimately saves labor time, cost, and machine downtime during the cleaning process.

Electric

Electricity drawn directly from ice machine.

Bulb Replacement

To retain maximum effectiveness, annual replacement of the internal UV bulb is recommended. UV bulb shelf life is 3 years from date of manufacture.





How LuminIce Works

UV light acts on the oxygen, nitrogen, and water vapor in the air stream passing across the bulb to create photoplasma.

Photoplasma is a gas that is fully ionized by UV light containing ions, free electrons, hydroxyl radicals, and ozone. Each of which is highly reactive with any microorganisms it encounters within the foodzone. This "active air" is continually recirculated within the foodzone inhibiting microorganism growth.

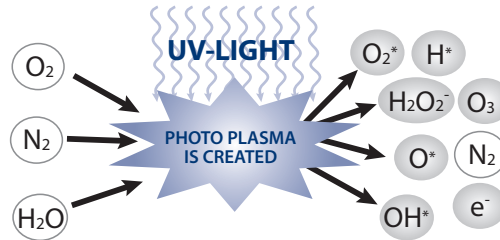

LuminIce (Internal Mounting)

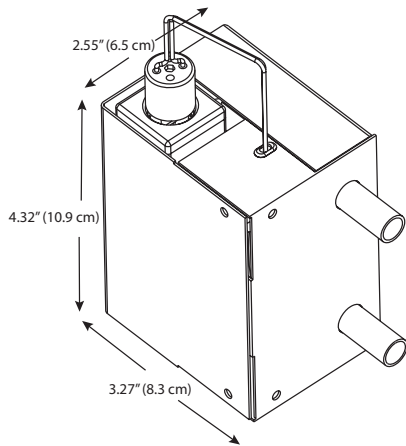

LuminIce UV Bulb

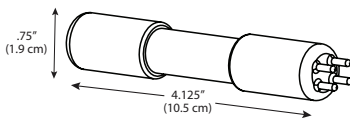

Cleaner Ice Machine Foodzones

Confirmed by Independent Testing Lab

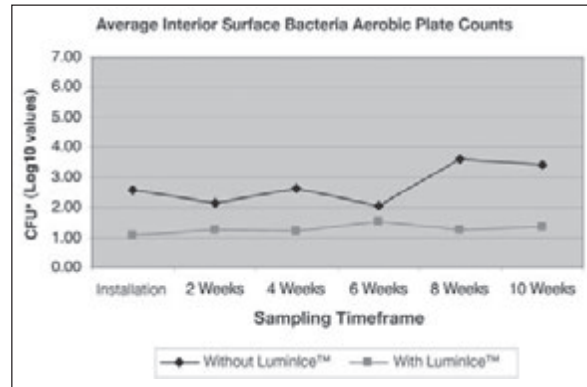
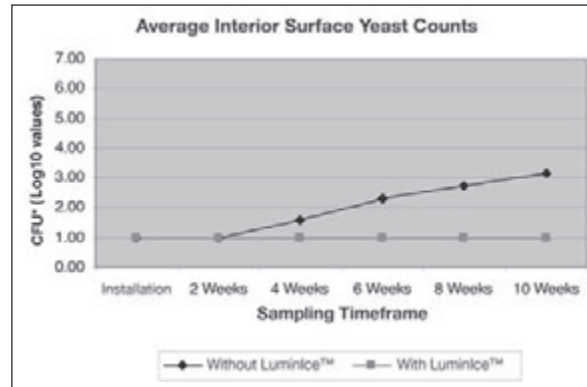

*Average foodzone Colony Forming Units (CFU's) plotted over time from date of installation.

LuminIce Models / Replacement Bulb

Model	Description
X	Factory Built-In LuminIce Growth Inhibitor. Comes pre-installed in ice machine. (Add "X" to end of Indigo model number)
K-00424	LuminIce Growth Inhibitor Kit for Indigo i-300 to i-1200, and QuietQube i-680C to i-1070C.
K-00434	LuminIce Growth Inhibitor Kit for Indigo IB Series, QuietQube i-1470C, i-1870C, i-2170C and 48" i-1400 and i-1800 models.
K-00425	Replacement LuminIce Bulb