



Restaurant Range - 60" - 10 Burners

Compact Design with High Output

Restaurant Range Series provides as standard many of the optional upgrades normally offered at a premium on other range lines. The standard include a stainless steel front, ledge, backguard and shelf; aluminized sides. The stainless steel seams and edges are welded so the range looks as good as it performs.

Standard Features Include:

- 2 - 26 1/2" ovens with 10 burners
- Chrome plated rack with support rack guides allowing up to two rack positions in each oven
- 5" stainless steel ledge for more usable working area
- Standard 30,000 BTU anti-clogging burner with built-in pilot shield
- Exclusive double-wall oven flame spreader with temperature diverters to increase even distribution of heat
- Oven's thermostat adjustable from low to 500 degrees
- 7" back shelf

Design Features:

- 12" x 12" heavy duty cast iron section grates remove easily and safely. Cast in bowl directs heat to the cooking surface.
- Grate design allows pots to slide from section to section
- 26 1/2" wide ovens are porcelainized on two contact surfaces for easy cleaning
- Unique burner baffle distributes heat flow evenly throughout the 30,000 BTU oven
- Oven door is removable for easy cleaning
- Stainless steel front, ledge, backguard and shelf
- Aluminized sides
- 5" wide stainless steel landing ledge provides a functional working area
- 7" deep shelf
- One year parts and labor warranty



60-CPGV-10B-S26

Options & Accessories:

- Casters - set of 6
- Additional racks

Certifications





Restaurant Range - 60" - 10 Burners

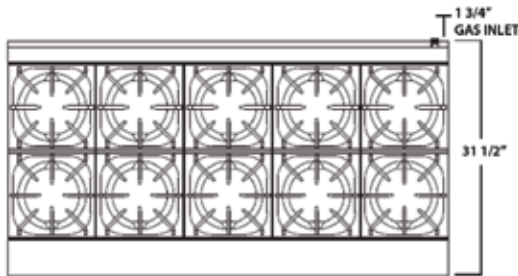

PRODUCT SPECIFICATIONS

Construction:

16 gauge construction with welded front frame. Fully insulated with non-sag fiberglass. Porcelainized oven deck and door linings. Equipped with one heavy-duty locking chrome plated rack with two guide positions.

Clearance:

For use only on non-combustible surfaces. Legs or stands are required, or 2" overhang is required when curb mounted. Provide 0" clearance from non-combustible surfaces and 4" from back, 10" from sides from combustible surfaces.

Gas Information:

Manifold pressure is 5.0"W.C. for natural gas or 10.0" for propane gas. Manifold size is 3/4" NPT. 3/4" pressure regulator supplied with equipment to be installed at time of connection. (Must specify type of gas and elevation if over 2,000 ft. when ordering.)

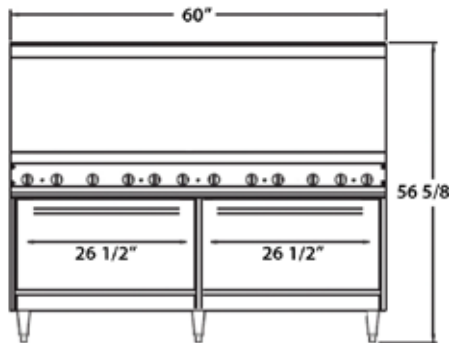

60-CPGV-10B-S26

10 burner, 26 1/2" Standard Oven (2), 360,000 BTU

Overall Dimensions:

60-CPGV-10B-S26: 60"W x 31 1/2"D x 56 5/8"H

Shipping:

60-CPGV-10B-S26: 995 lbs

Freight Class: 85

