



**TRUE FOOD SERVICE  
EQUIPMENT, INC.**

2001 East Terra Lane • O'Fallon, Missouri 63366  
(636)240-2400 • Fax (636)272-2408 • (800)325-6152 • Intl Fax# (001)636-272-7546  
Parts Dept. (800)424-TRUE • Parts Dept. Fax# (636)272-9471 • www.truemfg.com

Project Name: \_\_\_\_\_

Location: \_\_\_\_\_

Item #: \_\_\_\_\_ Qty: \_\_\_\_\_

Model #: \_\_\_\_\_

A/A #

S/S #

Model:  
**TUC-60D-4**

**Undercounter:**  
*Drawered Refrigerator*



**TUC-60D-4**

- ▶ True's undercounter units are designed with enduring quality that protects your long term investment.
- ▶ Designed using the highest quality materials and components to provide the user with colder product temperatures, lower utility costs, exceptional food safety and the best value in today's food service marketplace.
- ▶ Oversized, environmentally friendly (134A) forced-air refrigeration system holds 33°F to 38°F (.56°C to 3.33°C).
- ▶ All stainless steel front, top and ends. Matching aluminum finished back.
- ▶ Front breathing.
- ▶ Each drawer accommodates one (1) full size 12L "x 20"W x 6"D (305 mm x 508 mm x 153 mm) food pan (sold separately).
- ▶ Foamed-in-place using Ecomate. A new, innovative, high density, polyurethane insulation that has zero ozone depletion potential (ODP) and zero global warming potential (GWP).

**ROUGH-IN DATA**

Specifications subject to change without notice.  
Chart dimensions rounded up to the nearest 1/8" (millimeters rounded up to next whole number).

Model	Drawers	Cabinet Dimensions (inches) (mm)			HP	Voltage	Amps	NEMA Config.	Cord Length (total ft.) (total m)	Crated Weight (lbs.) (kg)
		L	D†	H*						
TUC-60D-4	4	60 3/8	30 1/8	29 3/4	1/5	115/60/1	5.1	5-15P	7	380
		1534	766	756	1/5	230-240/50/1	4.2	▲	2.13	173

† Depth does not include 1" (26 mm) for rear bumpers and 1/8" (4 mm) for door handle.  
\* Height does not include 6 1/4" (159 mm) for castors or 6" (153 mm) for optional legs.

▲ Plug type varies by country.

Printed in U.S.A.

**APPROVALS:**

**AVAILABLE AT:**



**TRUE FOOD SERVICE  
EQUIPMENT, INC.**

2001 East Terra Lane • O'Fallon, Missouri 63366  
(636)240-2400 • Fax (636)272-2408 • (800)325-6152 • Intl Fax# (001)636-272-7546  
Parts Dept. (800)424-TRUE • Parts Dept. Fax# (636)272-9471 • www.truemfg.com

Project Name: \_\_\_\_\_

Location: \_\_\_\_\_

Item #: \_\_\_\_\_ Qty: \_\_\_\_\_

Model #: \_\_\_\_\_

A/A #

S/S #

Model:  
**TUC-60D-4**

**Undercounter:**  
*Drawered Refrigerator*



**TUC-60D-4**

- ▶ True's undercounter units are designed with enduring quality that protects your long term investment.
- ▶ Designed using the highest quality materials and components to provide the user with colder product temperatures, lower utility costs, exceptional food safety and the best value in today's food service marketplace.
- ▶ Oversized, environmentally friendly (134A) forced-air refrigeration system holds 33°F to 38°F (.56°C to 3.33°C).
- ▶ All stainless steel front, top and ends. Matching aluminum finished back.
- ▶ Front breathing.
- ▶ Each drawer accommodates one (1) full size 12L "x 20"W x 6"D (305 mm x 508 mm x 153 mm) food pan (sold separately).
- ▶ Foamed-in-place using Ecomate. A new, innovative, high density, polyurethane insulation that has zero ozone depletion potential (ODP) and zero global warming potential (GWP).

**ROUGH-IN DATA**

Specifications subject to change without notice.  
Chart dimensions rounded up to the nearest 1/8" (millimeters rounded up to next whole number).

Model	Drawers	Cabinet Dimensions (inches) (mm)			HP	Voltage	Amps	NEMA Config.	Cord Length (total ft.) (total m)	Crated Weight (lbs.) (kg)
		L	D†	H*						
TUC-60D-4	4	60 3/8	30 1/8	29 3/4	1/5	115/60/1	5.1	5-15P	7	380
		1534	766	756	1/5	230-240/50/1	4.2	▲	2.13	173

† Depth does not include 1" (26 mm) for rear bumpers and 1/8" (4 mm) for door handle.  
\* Height does not include 6 1/4" (159 mm) for castors or 6" (153 mm) for optional legs.

▲ Plug type varies by country.



Printed in U.S.A.

**APPROVALS:**

**AVAILABLE AT:**

Model:  
**TUC-60D-4**

**Undercounter:**  
*Drawered Refrigerator*



**STANDARD FEATURES**

**DESIGN**

- True's commitment to using the highest quality materials and oversized refrigeration systems provides the user with colder product temperatures, lower utility costs, exceptional food safety and the best value in today's food service marketplace.

**REFRIGERATION SYSTEM**

- Factory engineered, self-contained, capillary tube system using environmentally friendly (CFC free) 134A refrigerant.
- Oversized, factory balanced refrigeration system with guided airflow to provide uniform product temperatures.
- Extra large evaporator coil balanced with higher horsepower compressor and large condenser; maintains cabinet temperatures of 33°F to 38°F (.5°C to 3.3°C) for the best in food preservation.
- Sealed, cast iron, self-lubricating evaporator fan motor(s) and larger fan blades give True undercounter units a more efficient, low velocity, high volume airflow design. This unique design ensures faster temperature recovery and shorter run times in the busiest of food service environments.
- Condensing unit access in back of cabinet, slides out for easy maintenance.

**CABINET CONSTRUCTION**

- Exterior - stainless steel front, top and ends. Matching aluminum finished back.
- Interior - attractive, NSF approved, white aluminum liner. 300 series stainless steel floor with coved corners.

- Insulation - entire cabinet structure and drawer facings are foamed-in-place using Ecomate. A new, innovative, high density, polyurethane insulation that has zero ozone depletion potential (ODP) and zero global warming potential (GWP).
- 5" (127 mm) diameter stem castors - locks provided on front set. 36" (915 mm) work surface height.

**DRAWERS**

- Stainless steel exterior drawer facings and liners. Stainless steel drawer frames.
- Each drawer fitted with 12" (305 mm) long recessed handle that is foamed-in-place with a sheet metal interlock to ensure permanent attachment.
- Magnetic drawer gaskets of one piece construction, removable without tools for ease of cleaning.
- Heavy-duty stainless steel drawer slides and rollers. Removable without tools for easy cleaning.
- Each drawer accommodates one (1) full size 12"L x 20"W x 6"D (305 mm x 508 mm x 153 mm) food pan (sold separately). Drawer will support varying size pan configurations with pan divider bars (drawer pans and divider bars optional).

**MODEL FEATURES**

- Evaporator is epoxy coated to eliminate the potential of corrosion.
- NSF-7 compliant for open food product.

**ELECTRICAL**

- Unit completely pre-wired at factory and ready for final connection to a 115/60/1 phase, 15 amp dedicated outlet. Cord and plug set included.



115/60/1  
NEMA-5-15R

**OPTIONAL FEATURES/ACCESSORIES**

Upcharge and lead times may apply.

- 230 - 240V / 50 Hz.
- 6" (153 mm) standard legs.
- 6" (153 mm) seismic/flanged legs.
- 2 1/2" (64 mm) diameter castors.
- Single overshelf.
- Double overshelf.
- TUC-27 Stacking collar.
- 30" (762 mm) deep, 1/2" (13 mm) thick, white polyethylene cutting board. Requires "L" brackets.
- 30" (762 mm) deep, 1/2" (13 mm) thick, composite cutting board. Requires "L" brackets.
- Heavy duty, 16 gauge tops.
- Exterior rectangular digital temperature display (factory installed).
- ADA compliant models with 34" (864 mm) work surface height.
- Low profile models with 31 7/8" (810 mm) work surface height.
- Remote cabinets (condensing unit supplied by others; system comes standard with 404A expansion valve and requires R404A refrigerant). Consult factory technical service department for BTU information. All remote units must be hard wired during installation.

**PLAN VIEW**

CUBIC FEET 15.5

\* Based on ANSI/AHAM HRF-1-2004

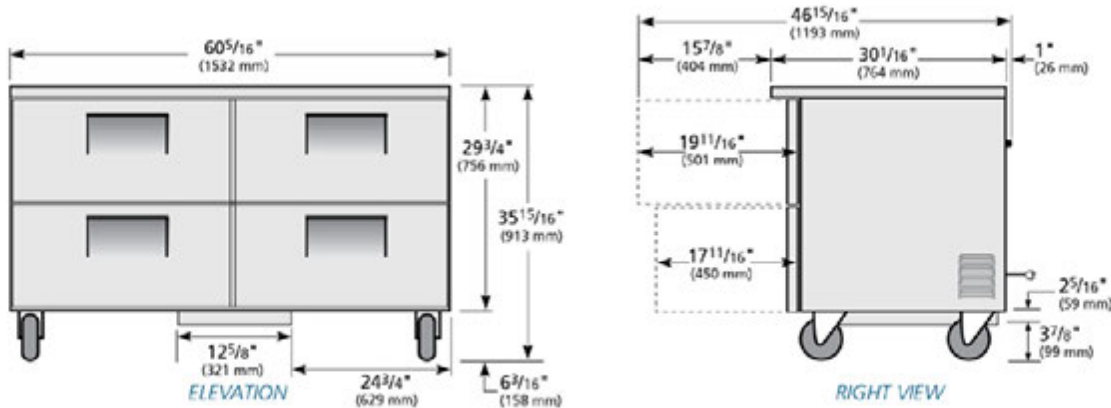

**WARRANTY**

One year warranty on all parts and labor and an additional 4 year warranty on compressor. (U.S.A. only)

METRIC DIMENSIONS ROUNDED UP TO THE NEAREST WHOLE MILLIMETER

SPECIFICATIONS SUBJECT TO CHANGE WITHOUT NOTICE



Model	Elevation	Right	Plan	3D	Back
TUC-60D-4	TFQY07E	TFQY05S	TFQY07P	TFQY073	

**TRUE FOOD SERVICE EQUIPMENT**

2001 East Terra Lane • O'Fallon, Missouri 63366 • (636)240-2400 • Fax (636)272-2408 • (800)325-6152 • Intl. Fax# (001)636-272-7546 • www.truefmfg.com

Model:  
**TUC-60D-4**

**Undercounter:**  
*Drawered Refrigerator*



**STANDARD FEATURES**

**DESIGN**

- True's commitment to using the highest quality materials and oversized refrigeration systems provides the user with colder product temperatures, lower utility costs, exceptional food safety and the best value in today's food service marketplace.

**REFRIGERATION SYSTEM**

- Factory engineered, self-contained, capillary tube system using environmentally friendly (CFC free) 134A refrigerant.
- Oversized, factory balanced refrigeration system with guided airflow to provide uniform product temperatures.
- Extra large evaporator coil balanced with higher horsepower compressor and large condenser; maintains cabinet temperatures of 33°F to 38°F (.5°C to 3.3°C) for the best in food preservation.
- Sealed, cast iron, self-lubricating evaporator fan motor(s) and larger fan blades give True undercounter units a more efficient, low velocity, high volume airflow design. This unique design ensures faster temperature recovery and shorter run times in the busiest of food service environments.
- Condensing unit access in back of cabinet, slides out for easy maintenance.

**CABINET CONSTRUCTION**

- Exterior - stainless steel front, top and ends. Matching aluminum finished back.
- Interior - attractive, NSF approved, white aluminum liner. 300 series stainless steel floor with coved corners.

- Insulation - entire cabinet structure and drawer facings are foamed-in-place using Ecomate. A new, innovative, high density, polyurethane insulation that has zero ozone depletion potential (ODP) and zero global warming potential (GWP).
- 5" (127 mm) diameter stem castors - locks provided on front set. 36" (915 mm) work surface height.

**DRAWERS**

- Stainless steel exterior drawer facings and liners. Stainless steel drawer frames.
- Each drawer fitted with 12" (305 mm) long recessed handle that is foamed-in-place with a sheet metal interlock to ensure permanent attachment.
- Magnetic drawer gaskets of one piece construction, removable without tools for ease of cleaning.
- Heavy-duty stainless steel drawer slides and rollers. Removable without tools for easy cleaning.
- Each drawer accommodates one (1) full size 12"L x 20"W x 6"D (305 mm x 508 mm x 153 mm) food pan (sold separately). Drawer will support varying size pan configurations with pan divider bars (drawer pans and divider bars optional).

**MODEL FEATURES**

- Evaporator is epoxy coated to eliminate the potential of corrosion.
- NSF-7 compliant for open food product.

**ELECTRICAL**

- Unit completely pre-wired at factory and ready for final connection to a 115/60/1 phase, 15 amp dedicated outlet. Cord and plug set included.



115/60/1  
NEMA-5-15R

**OPTIONAL FEATURES/ACCESSORIES**

Upcharge and lead times may apply.

- 230 - 240V / 50 Hz.
- 6" (153 mm) standard legs.
- 6" (153 mm) seismic/flanged legs.
- 2 1/2" (64 mm) diameter castors.
- Single overshelf.
- Double overshelf.
- TUC-27 Stacking collar.
- 30" (762 mm) deep, 1/2" (13 mm) thick, white polyethylene cutting board. Requires "L" brackets.
- 30" (762 mm) deep, 1/2" (13 mm) thick, composite cutting board. Requires "L" brackets.
- Heavy duty, 16 gauge tops.
- Exterior rectangular digital temperature display (factory installed).
- ADA compliant models with 34" (864 mm) work surface height.
- Low profile models with 31 7/8" (810 mm) work surface height.
- Remote cabinets (condensing unit supplied by others; system comes standard with 404A expansion valve and requires R404A refrigerant). Consult factory technical service department for BTU information. All remote units must be hard wired during installation.

**PLAN VIEW**

CUBIC FEET 15.5

\* Based on ANSI/AHAM HRF-1-2004

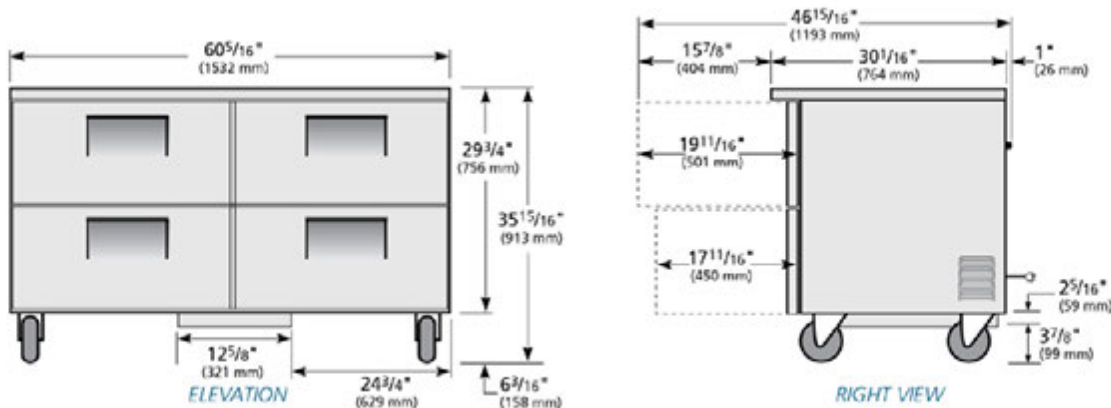

**WARRANTY**  
One year warranty on all parts and labor and an additional 4 year warranty on compressor. (U.S.A. only)

METRIC DIMENSIONS ROUNDED UP TO THE NEAREST WHOLE MILLIMETER  
SPECIFICATIONS SUBJECT TO CHANGE WITHOUT NOTICE



Model	Elevation	Right	Plan	3D	Back
TUC-60D-4	TFQY07E	TFQY05S	TFQY07P	TFQY073	

**TRUE FOOD SERVICE EQUIPMENT**

2001 East Terra Lane • O'Fallon, Missouri 63366 • (636)240-2400 • Fax (636)272-2408 • (800)325-6152 • Intl. Fax# (001)636-272-7546 • www.truefmfg.com