



TRUE FOOD SERVICE EQUIPMENT, INC.

2001 East Terra Lane • O'Fallon, Missouri 63366
 (636)240-2400 • Fax (636)272-2408 • (800)325-6152 • Intl Fax# (001)636-272-7546
 Parts Dept. (800)424-TRUE • Parts Dept. Fax# (636)272-9471 • www.truemfg.com

Project Name: _____

Location: _____

Item #: _____ Qty: _____

Model #: _____

A/A #

S/S #

Model:
TSSU-72-12-ADA

Food Prep Table:
ADA Compliant Solid Door Sandwich/Salad Unit



TSSU-72-12-ADA

- ▶ 3" (77 mm) diameter stem castors standard. Work surface 34" (864 mm) high to comply with the Americans with Disabilities Act (ADA) requirements.
- ▶ Oversized, environmentally friendly (134A), patented forced-air refrigeration system holds 33°F to 41°F (.5°C to 5°C).
- ▶ Complies with and listed under ANSI/NSF-7-1997-6.3.
- ▶ All stainless steel front, top and ends. Matching aluminum finished back.
- ▶ Stainless steel, patented, foam insulated lid(s) and hood keep pan temperatures colder, lock in freshness and minimize condensation. Removable for easy cleaning.
- ▶ 11 ¾" (299 mm) deep full length removable cutting board included. Sanitary, high density, NSF approved white polyethylene provides tough preparation surface.
- ▶ Foamed-in-place using Ecomate. A high density, polyurethane insulation that has zero ozone depletion potential (ODP) and zero global warming potential (GWP).
- ▶ Heavy duty PVC coated wire shelves.

ROUGH-IN DATA

Specifications subject to change without notice.
 Chart dimensions rounded up to the nearest 1/8" (millimeters rounded up to next whole number).

Model	Doors	Shelves	Pans (top)	Cabinet Dimensions (inches) (mm)			Counter Height	HP	Voltage	Amps	NEMA Config.	Cord Length (total ft.) (total m)	Crated Wt. (lbs.) (kg)
				L	D†	H*							
TSSU-72-12-ADA	3	6	12	72¾ 1839	30⅞ 766	36¾ 934	34	½ ½	115/60/1 230-240/50/1	10.3 6.7	5-15P ▲	7 2.13	N/A N/A

† Depth does not include 1" (26 mm) for rear bumpers.
 * Height does not include 4" (1102 mm) for castors.

▲ Plug type varies by country.

	APPROVALS:	AVAILABLE AT:
	5/10 Printed in U.S.A.	

Model:
TSSU-72-12-ADA

Food Prep Table: ADA Compliant Solid Door Sandwich/Salad Unit



STANDARD FEATURES

DESIGN

- True's salad/sandwich units are designed with enduring quality that protects your long term investment.
- True's commitment to using the highest quality materials and oversized refrigeration systems provides the user with colder product temperatures, lower utility costs, exceptional food safety and the best value in today's food service marketplace.

REFRIGERATION SYSTEM

- Self-contained, factory pre-engineered capillary tube system using environmentally friendly (CFC free) 134A refrigerant.
- Oversized, factory balanced refrigeration system with guided airflow to provide uniform temperature in food pans and cabinet interior.
- Patented forced-air design holds 33°F to 41°F (5°C to 5°C) product temperature in food pans and cabinet interior. Complies with and listed under ANSI/NSF-7-1997-6.3.
- Sealed, cast iron, self-lubricating evaporator fan motor(s) and larger fan blades give True undercounter units a more efficient, low velocity, high volume airflow design.
- Condensing unit access in back of cabinet, slides out for easy maintenance.

CABINET CONSTRUCTION

- Exterior - stainless steel front, top and ends. Matching aluminum finished back.
- Interior - attractive, NSF approved, white aluminum liner. 300 series stainless steel floor with coved corners.
- Insulation - entire cabinet structure and solid doors are foamed-in-place using Ecomate. A high density, polyurethane insulation that has zero ozone depletion potential (ODP) and zero global warming potential (GWP).
- 3" (77 mm) diameter stem castors. 34" (864 mm) work surface height.

DOORS

- Stainless steel exterior with white aluminum liner to match cabinet interior.
- Each door fitted with 12" (305 mm) long recessed handle that is foamed-in-place with a sheet metal interlock to ensure permanent attachment.
- Positive seal self-closing doors with 90° stay open feature. Doors swing within cabinet dimensions.
- Magnetic door gaskets of one piece construction, removable without tools for ease of cleaning.

SHELVING

- Six (6) adjustable, heavy duty PVC coated wire shelves. Two (2) right and two (2) left door shelf dimensions are 21³/₁₆" L x 16" D (548 mm x 407 mm). Two (2) center door shelf dimensions are 23¹/₂" L x 16" D (597 mm x 407 mm). Four (4) chrome plated shelf clips included per shelf.
- Shelf support pilasters made of same material as cabinet interior; shelves are adjustable on 1/2" (13 mm) increments.

DRAWER PAN CAPACITY

- Comes standard with 18 (1/2 size) 6⁷/₈" L x 6¹/₄" W x 4" D (175 mm x 159 mm x 102 mm) clear polycarbonate, NSF approved, food pans in countertop prep area. Also accommodates 6" (153 mm) and 8" (204 mm) deep food pans (supplied by others).
- Countertop pan opening designed to fit varying size pan configurations with available pan divider bars. Pans supplied by others.

MODEL FEATURES

- Evaporator is epoxy coated to eliminate the potential of corrosion.
- 11³/₄" (299 mm) deep full length removable cutting board included. Sanitary, high-density, NSF approved white polyethylene provides tough preparation surface.

- Stainless steel, patented, foam insulated lids and hood keep pan temperatures colder, lock in freshness and minimize condensation. Removable for easy cleaning.
- NSF-7 compliant for open food product.

ELECTRICAL

- Unit completely pre-wired at factory and ready for final connection to a 115/60/1 phase, 15 amp dedicated outlet. Cord and plug set included.



OPTIONAL FEATURES/ACCESSORIES

Upcharge and lead times may apply.

- 230 - 240V / 50 Hz.
- Barrel locks (factory installed). Requires one per door.
- Additional shelves.
- Single overshef.
- Double overshef.
- Flat lid.
- Sneezeguard.
- 19" (483 mm) deep, 1/2" (13 mm) thick, white polyethylene cutting board. Requires "L" brackets.
- 19" (483 mm) deep, 3/4" (20 mm) thick, white polyethylene cutting board. Requires "L" brackets.
- 11³/₄" (299 mm) deep, 1/2" (13 mm) thick, composite cutting board. Requires "L" brackets.
- 19" (483 mm) deep, 1/2" (13 mm) thick, composite cutting board. Requires "L" brackets.
- Crumb catcher. Requires crumb catcher cutting board for proper installation.
- Pan dividers.
- Exterior rectangular digital thermometer (factory installed).
- Standard height unit with 5" (127 mm) diameter castors. 36" (915 mm) work surface height.

PLAN VIEW

Cubic Feet/Liters 19/538
* Based on ANSI/AHAM HRF-1-2004

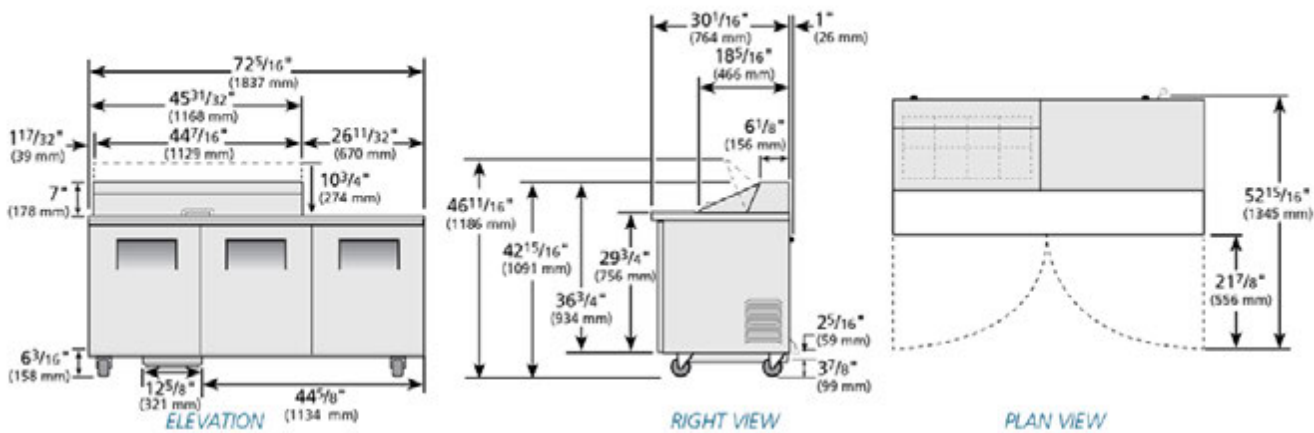

WARRANTY
 One year warranty on all parts and labor and an additional 4 year warranty on compressor. (U.S.A. only) -

METRIC DIMENSIONS ROUNDED UP TO THE NEAREST WHOLE MILLIMETER -
 SPECIFICATIONS SUBJECT TO CHANGE - WITHOUT NOTICE -

	Model	Elevation	Right	Plan	3D
	TSSU-72-12-ADA	TFNY067E	TFNY67S	TFNY31P	TFNY0673

TRUE FOOD SERVICE EQUIPMENT

2001 East Terra Lane • O'Fallon, Missouri 63366 • (636)240-2400 • Fax (636)272-2408 • (800)325-6152 • Intl. Fax# (001)636-272-7546 • www.truemfg.com