



**TRUE FOOD SERVICE
EQUIPMENT, INC.**

2001 East Terra Lane • P.O. Box 970 • O'Fallon, Missouri 63366
(636)240-2400 • Fax (636)272-2408 • (800)325-6152 • Intl Fax# (001)636-272-7546
Parts Dept. (800)424-TRUE • Parts Dept. Fax# (636)272-9471 • www.truemfg.com

Project Name: _____

Location: _____

Item #: _____ Qty: _____

Model #: _____

A/A #

S/S #

Model:
TUC-48D-4-ADA

Undercounter:
ADA Compliant Drawered Sandwich/Salad Unit



TUC-48D-4-ADA

- ▶ Designed using the highest quality materials and components to provide the user with colder product temperatures, lower utility costs, exceptional food safety and the best value in today's food service marketplace.
- ▶ 3" (77 mm) diameter stem castors standard. 34" (864 mm) work surface height. Complies with the Americans with Disabilities Act (ADA) requirements.
- ▶ Oversized, environmentally friendly (134A) forced-air refrigeration system holds 33°F to 38°F (.5°C to 3.3°C).
- ▶ All stainless steel front, top and ends. Matching aluminum finished back.
- ▶ Front breathing.
- ▶ Each drawer accommodates one (1) full size 12"L x 18"W x 6"D (305 mm x 458 mm x 153 mm) food storage box (sold separately).
- ▶ Foamed-in-place, high density polyurethane insulation (CFC free).

ROUGH-IN DATA

Specifications subject to change without notice.
Chart dimensions rounded up to the nearest 1/8" (millimeters rounded up to next whole number).

Model	Drawers	Capacity (Cu. Ft.) (liters)	Cabinet Dimensions (inches) (mm)			Counter Height	HP	Voltage	Amps	NEMA Config.	Cord Length (total ft.) (total m)	Crated Weight (lbs.) (kg)
			L	D†	H*							
TUC-48D-4-ADA	4	12	48 3/8	30 1/8	29 3/4	34	1/5	115/60/1	5	5-15P	7	310
		430	1229	766	756		1/3	230-240/50/1				

† Depth does not include 1" (26 mm) for rear bumpers.
* Height does not include 4" (1102 mm) for castors.

▲ Plug type varies by country.

	<p>APPROVALS:</p>	<p>AVAILABLE AT:</p>
<p>Printed in U.S.A.</p>		

Model:
TUC-48D-4-ADA

Undercounter:
ADA Compliant Drawered Sandwich/Salad Unit



STANDARD FEATURES

DESIGN

- True's undercounter units are designed with enduring quality that protects your long term investment.
- True's commitment to using the highest quality materials and oversized refrigeration systems provides the user with colder product temperatures, lower utility costs, exceptional food safety and the best value in today's food service marketplace.

REFRIGERATION SYSTEM

- Factory engineered, self-contained, capillary tube system using environmentally friendly (CFC free) 134A refrigerant.
- Oversized, factory balanced refrigeration system with guided airflow to provide uniform product temperatures.
- Extra large evaporator coil balanced with higher horsepower compressor and large condenser maintains cabinet temperatures of 33°F to 38°F (.56°C to 3.33°C) for the best in food preservation.
- Sealed, cast iron, self-lubricating evaporator fan motor(s) and larger fan blades give True undercounter units a more efficient, low velocity, high volume airflow design. This unique design ensures faster temperature recovery and shorter run times in the busiest of foodservice environments.
- Condensing unit access in back of cabinet, slides out for easy maintenance.

CABINET CONSTRUCTION

- Exterior - stainless steel front, top and ends. Matching aluminum finished back.
- Interior - attractive, NSF approved, white aluminum liner. 300 series stainless steel floor with coved corners.
- Insulation - entire cabinet structure and drawer facings are foamed-in-place using high density, CFC free, polyurethane insulation.

- 3" (77 mm) diameter stem castors. 34" (864 mm) work surface height. Compliant with American Disabilities Act (ADA) requirements.

DRAWERS

- Stainless steel exterior drawer facings and liners. Stainless steel drawer frames.
- Each drawer fitted with 12" (305 mm) long recessed handle that is foamed-in-place with a sheet metal interlock to ensure permanent attachment.
- Magnetic drawer gaskets of one piece construction, removable without tools for ease of cleaning.
- Heavy-duty stainless steel drawer slides and rollers. Removable without tools for easy cleaning.
- Each drawer accommodates one (1) full size 12"L x 18"W x 6"D (305 mm x 458 mm x 153 mm) food storage box or one 1/2 size and one 1/2 size pan (sold separately).

MODEL FEATURES

- Evaporator is epoxy coated to eliminate the potential of corrosion.
- NSF-7 compliant for open food product.

ELECTRICAL

- Unit completely pre-wired at factory and ready for final connection to a 115/60/1 phase, 15 amp dedicated outlet. Cord and plug set included.



- Heavy duty 16 gauge top.
- Exterior rectangular digital temperature display (factory installed).
- Standard height units with 5" (127 mm) diameter castors. 36" (915 mm) work surface height.
- Low profile models with 3 1/8" (810 mm) work surface height.

OPTIONAL FEATURES/ACCESSORIES

Upcharge and lead times may apply.

- 230 - 240V / 50 Hz.
- Single overshef.
- Double overshef.
- Stacking collar.
- 30" (762 mm) deep, 1/2" (13 mm) thick, white polyethylene cutting board. Requires "L" brackets.
- 30" (762 mm) deep, 1/2" (13 mm) thick, composite cutting board. Requires "L" brackets.

PLAN VIEW

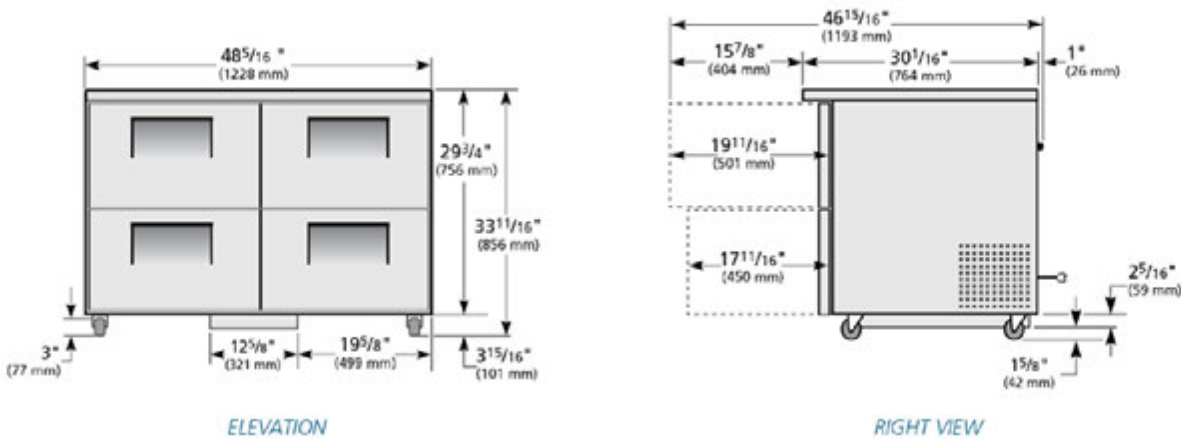

WARRANTY
One year warranty on all parts and labor and an additional 4 year warranty on compressor. (U.S.A. only) -

METRIC DIMENSIONS ROUNDED UP TO THE NEAREST WHOLE MILLIMETER -
SPECIFICATIONS SUBJECT TO CHANGE - WITHOUT NOTICE -

	Model	Elevation	Right	Plan	3D	Back
	TUC-48D-4-ADA	TFQY27E	TFQY17S	TFQY06P	TFQY273	

TRUE FOOD SERVICE EQUIPMENT

2001 East Terra Lane • P.O. Box 970 • O'Fallon, Missouri 63366 • (636)240-2400 • Fax (636)272-2408 • (800)325-6152 • Intl. Fax# (001)636-272-7546 • www.truefmfg.com

Central Restaurant Products