



Follow the Leader™

Floral • Deli • Seafood • Meat • Bakery • Produce • Front End

INTRODUCING The *Mist-O-Matic*™ Heavy Duty Single Door Roll-In Rack Proofer

Unisource with its 25 years of experience has solved all your common Proofer problems with these exclusive features:

Exclusive *Mist-O-Matic*™ Soft Air Humidification System eliminates lime and mineral build up because nozzle does not spray directly on heating elements. It also prevents brown discoloring inside the Proofer and insures consistent temperature and humidity.

Features:

- LED Digital easy to use controller
- Full stainless steel construction
- 300 series stainless steel interior
- 400 series stainless steel exterior
- Mist-O-Matic™ Soft Air Humidification System
- Modular cam lock wall and roof construction
- Interior and exterior bumper guards
- Accommodates up to 74" tall racks
- 2" polyurethane insulated wall/roof panels
- Eye level digital control panel features:
 - Temperature control
 - Humidity control
 - Countdown timers
 - Main power switch
 - Lighted Interior
- 70° F - 120° F proofing Range
- 50 - 99% Humidity Range
- Three heavy duty cam lift hinges (w/stay Models: open feature) per door
- Fully Automatic Proofer
- Multiple depths available
- One year parts/labor warranty
- 24/7 Nationwide Service

Options:

- Heavy Duty Stainless Steel Floor
- Pass-Through Option
- Prison Package



Mist-O-Matic™ Humidification System
eliminates lime build up and brown discoloring
inside the interior of proof box.

MODEL/RACK CAPACITY

Model / Depth	Side Load	End Load	Double
UNI-LRP1-40	1 Rack	1 Rack	None
UNI-LRP1-50	2 Racks	2 Racks	1 Rack
UNI-LRP1-60	2 Racks	2 Racks	1 Rack
UNI-LRP1-70	3 Racks	2 Racks	1 Rack
UNI-LRP1-80	3 Racks	3 Racks	1 Rack
UNI-LRP1-90	4 Racks	3 Racks	2 Racks
UNI-LRP1-100	4 Racks	4 Racks	2 Racks
UNI-LRP1-110	5 Racks	4 Racks	2 Racks
UNI-LRP1-120	5 Racks	5 Racks	3 Racks



Follow the Leader™

INSTALLATION REQUIREMENT

Requires on-site installation
 KD shipment
 1/2" NPT Cold water connection
 1/2" NPT vented drain connection
 Either 208 or 240 VAC 1 or 3-phase

OPTIONS & ACCESSORIES

Stainless Steel Floor

	A	B	C	D
UNI-LRP1-40	78	32.1	49.3	41
UNI-LRP1-50	88	42.1	59.3	51
UNI-LRP1-60	98	52.1	69.3	61
UNI-LRP1-70	108	62.1	79.3	71
UNI-LRP1-80	118	72.1	89.3	81
UNI-LRP1-90	128	82.1	99.3	91
UNI-LRP1-100	138	92.1	109.3	101
UNI-LRP1-110	148	102.1	119.3	111
UNI-LRP1-120	158	112.1	129.3	121

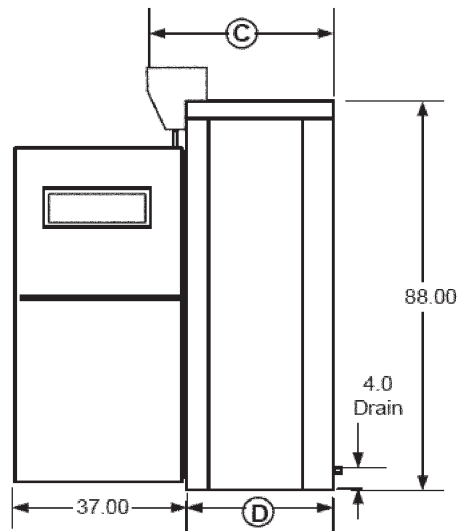
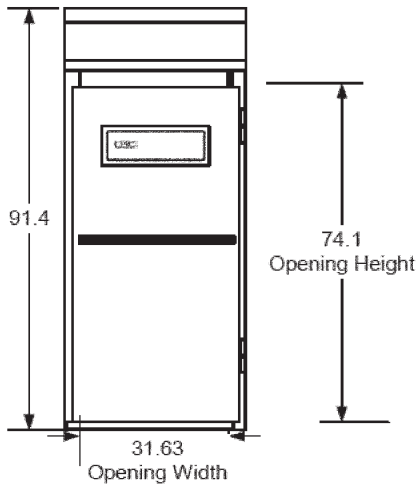
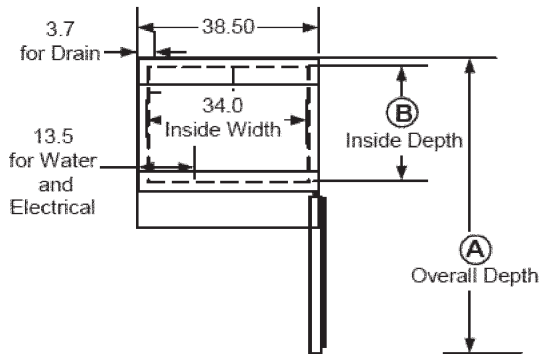

Model	Voltage	Total Kw	1-Phase	3-Phase	Water	Drain
UNI-LRP1(40-80)	208 VAC	5	24.0 AMPS	13.8 AMPS	1/2" NPT .07 GPM@60 PSI	1/2" PVC; 210 F; < 1 GPM MAX.
UNI-LRP1(40-80)	240 VAC	6.6	27.5 AMPS	15.8 AMPS		
UNI-LRP1(90-120)	208 VAC	5	24.0 AMPS	13.8 AMPS	1/2" NPT .07 GPM@60 PSI	1/2" PVC; 210 F; < 1 GPM MAX.
UNI-LRP1(90-120)	240 VAC	6.6	27.5 AMPS	13.8 AMPS		

IMPORTANT: Your local water conditions may damage your Unisource Proofer appliance. Failure to properly treat water may result in damage and may void your warranty. Ensure that your water supply meets these minimum water quality specification.

Parameter	Unit	Value	Parameter	Unit	Value
Alkalinity	ppm	22	Magnesium	ppm	0.65
Aluminium	ppb	17	pH	s.u.	8.5
Calcium	ppm	3.3	Sodium	ppm	8.5
Free Chlorine Residual	ppm	0.6	Total Hardness	ppm	11.9

Phone: (888) 443-8782 • Fax: (516) 681-0845 • email: info@unisourcefoodequipment.com • www.unisourcefoodequipment.com
 56 Rockland Drive, Jericho NY 11753