

Product Line	<b>Floor Mixer</b>	SPEC BABG20 03-2013
Model	<b>BABG-20</b>	

## BABG-20 Floor Mixer

**20-quart capacity**  
**Item#21698**

### Features

- 3 speed direct drive gear transmission
- Safety cut-switch automatically turns the unit off if gears are changed without stopping the mixer
- #12 hub
- Digital control
- Surface protection feet covers
- Comes standard with:
  - Dough hook
  - Wire whip
  - Flat beater
  - Stainless steel mixing bowl
  - Safety guard
- Heavy duty durable construction



- 5** Standard accessories:
- Stainless steel bowl
  - Wire whip
  - Dough hook
  - Beater
  - Bowl

### 90 Years of Quality Donut & Bakery Equipment

#### BELSHAW ADAMATIC BAKERY GROUP

814 44th St NW, Suite 103  
 Auburn, WA 98001 USA  
 PART OF ALI GROUP SPA

#### CONTACT

800.578.2547 (USA/CANADA)  
 (+1)206.322.5474 Worldwide  
 service@belshaw.com

#### WEB

www.belshaw-adamatic.com  
 www.belshaw.com  
 www.adamatic.com

SPEC BABG20 03-2013
---------------------------

Product Line	<b>Floor Mixer</b>	SPEC BABG20 03-2013
Model	<b>BABG-20</b>	

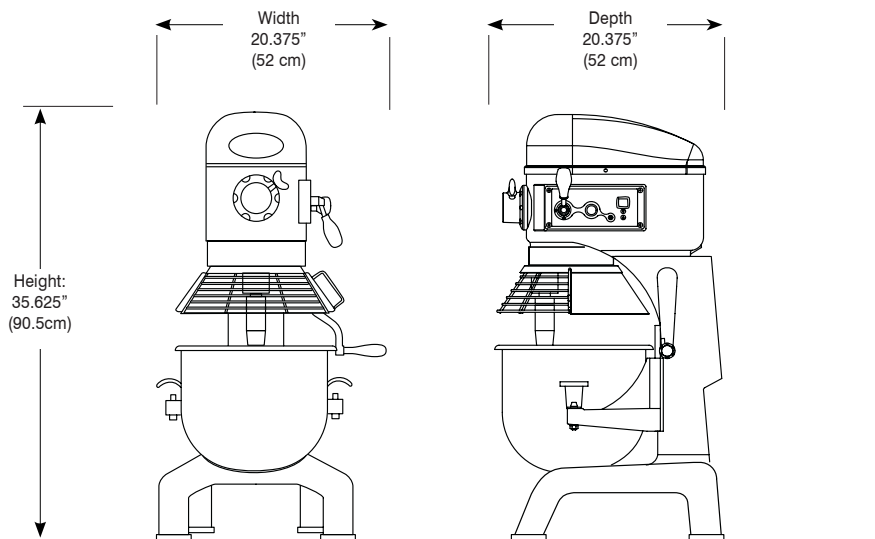

**CONTROL PANEL**

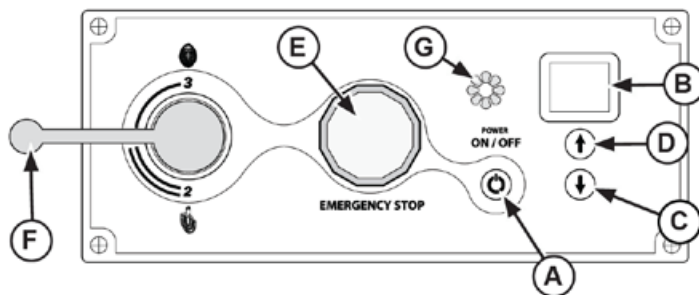

- (A) ON/OFF BUTTON**
- (B) DIGITAL DISPLAY**
  - Displays time remaining when in timed operation cycle
  - Displays "ON" when operating in a non-timed mode
  - Displays "OFF" when not operating
- (C) TIME UP BUTTON**
  - Increases the time. Maximum time of 30 minutes
- (D) TIME DOWN BUTTON**
  - Decreases the time
- (E) STOP BUTTON**
- (F) SPEED SELECT LEVER**
- (G) INDICATOR LIGHTS**
  - Lights are on when mixer is in operating mode.

**Dimensions & Weight**

- Width: 20.375" (52 cm)
- Depth: 20.375" (52 cm)
- Height: 35.625" (90.5cm)
- Net weight:
- 209 lbs (45 kg)
- Shipping weight
- 258 lbs (45 kg)

**Electrical**

- Volts: 110V
- Amps: 8A
- HP: 1/2 hp
- Plug: NEMA 5-15P

**Certifications**

- Certified by ETL, NSF



**90 Years of Quality Donut & Bakery Equipment**

**BELSHAW ADAMATIC BAKERY GROUP**

814 44th St NW, Suite 103  
Auburn, WA 98001 USA  
PART OF ALI GROUP SPA

**CONTACT**

800.578.2547 (USA/CANADA)  
(+1)206.322.5474 Worldwide  
service@belshaw.com

**WEB**

www.belshaw-adamatic.com  
www.belshaw.com  
www.adamatic.com

SPEC  
BABG20  
03-2013