



STANDARD SERIES UNDERBAR WALL MOUNT SOAP DISPENSER

MODEL: **H-104** PROJECT: _____ ITEM #: _____ QTY: _____

PRODUCT IMAGE



H-104 SHOWN

STANDARD FEATURES

- Mounts to the wall with 3 screws provided
- Easy to remove soap container by unscrewing from chrome plated base

SPECIFICATIONS

- Overall Height: 8 1/4"
- Overall Depth: 4 3/4"
- Soap Container Height: 5"
- Soap Container Width: 3 1/4"
- Shipping Weight: 0.5 lb.



APPROVED BY:

CERTIFICATIONS:

Due to our commitment to continued product improvement, specifications are subject to change without notice.

Printed in the USA

Krowne Metal Corporation

100 Haul Rd. Wayne, NJ 07470 • Toll Free: (800) 631-0442 • Fax: (973) 872-1129
sales@krowne.com • www.krowne.com • www.facebook.com/KrowneMetal • www.twitter.com/KrowneMetal

Rev. 09/2011
No. H-104



STANDARD SERIES UNDERBAR WALL MOUNT SOAP DISPENSER

MODEL: **H-104** PROJECT: _____ ITEM #: _____ QTY: _____

DRAWING

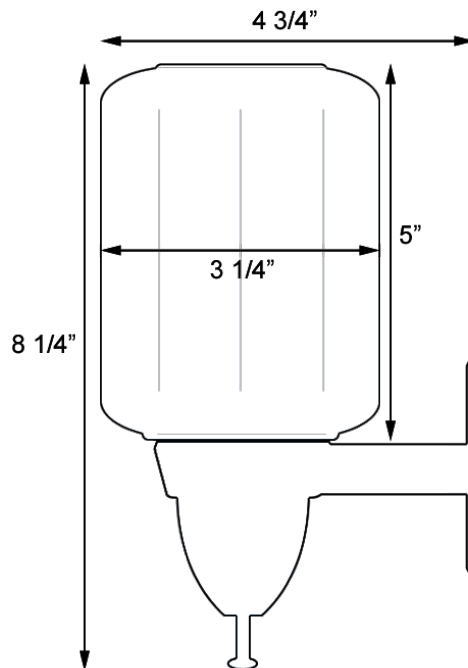

APPROVED BY:

CERTIFICATIONS:

Due to our commitment to continued product improvement, specifications are subject to change without notice.