

REFRIGERATOR MANUFACTURER
Turbo air
 more durable, convenient, beautiful

1250 Victoria St
 Carson, CA 90746
 Tel. 310-900-1000
 Fax. 310-900-1077
www.turboairinc.com

Project :	
Model # :	
Item # :	Qty :
Available W/H :	
Approval :	

Undercounter Freezer

Undercounters
M3 Series

Model : MUF-60



FEATURES / BENEFITS

■ **EFFICIENT REFRIGERATION SYSTEM**

M3's solid door freezers are designed with oversized and balanced (CFC Free R-404A) refrigeration systems. These include efficient evaporators and condensers for faster freezing and greater efficiency.

■ **STAINLESS STEEL CABINET CONSTRUCTION**

The Turbo Air M3 model boasts a stainless steel interior and exterior (except inside wall and the back). It guarantees the utmost in cleanliness and long product life. The M3 can add a touch of style to the most refined setting.

■ **HIGH-DENSITY POLYURETHANE INSULATION**

The entire cabinet structure and solid doors are foamed-in-place using high density, CFC free polyurethane insulation.

■ **ADJUSTABLE, HEAVY DUTY, PE (POLYETHYLENE) COATED WIRE SHELVES**

■ **ERGONOMICALLY DESIGNED DOORS**

Customers' fatigue fades away with easy grip handles and doors that open effortlessly. These features along with self-closing doors make this the ultimate choice in customer convenience. ABS sheet door liners resist water condensation with thermal efficiency.

■ **MAGNETIC DOOR GASKETS**

Magnetic door gaskets are of one piece construction, removable without tools for ease of cleaning and replacement.

■ **HOT GAS CONDENSATE SYSTEM**

Through Turbo Air's creative innovation, the condensate system surfaces have been specially treated to resist corrosion. This not only increases efficiency without the risk of refrigerant leakage from corrosion, but also prevents the overflow of condensate water.

■ **FREEZER HOLDS -5°F ~ -10°F FOR THE BEST IN FROZEN FOOD PRESERVATION**



Model	Swing Door	CU./FT.	#of Shelves	HP	AMPS	Crated Weight (lbs.)	L x D x H* (inches)
MUF-60	2	16	2	1/2	9	282	60 1/4 x 30 x 30

* Height does not include 6-1/2" for caster height.

Model : MUF-60

ELECTRICAL DATA	
Voltage	115/60/1
Plug Type	Ⓜ NEMA-5-15P
Full Load Amperes	9
Compressor HP	1/2
Cord Length ft.	9
Refrigerant	R-404A
DIMENSIONAL DATA	
Net Capacity cu. ft.	16
Ext. Length Overall in.	60 1/4 (1530mm)
Ext. Depth Overall in.	30 (762mm)
Ext. Height Overall in.*	30 (762mm)
# of Doors	2
# of Shelves	2
Gross Weight lbs.	282
Net Weight lbs.	260

Design and specifications subject to change without notice.

* Height does not include 6-1/2" for caster height.

■ **WARRANTY : 1 Year Parts and Labor Warranty**
Additional 4 Year Warranty on Compressor

■ **SELF-CONTAINED SYSTEM**

■ **5" SWIVEL CASTERS**

■ **OPTIONAL ACCESSORIES :**

- 2.5" Diameter casters
- 5" Diameter casters
- 6" ABS plastic legs
- Additional stainless steel shelves
- Additional PE coated wire shelves
- Stainless steel double over-shelf
- Back splash guard

PLAN VIEW

(unit : inch)

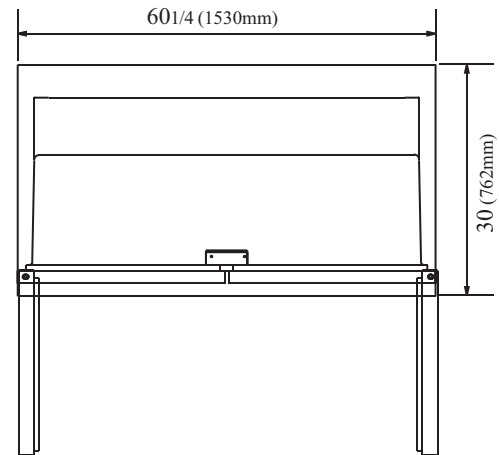

PLAN VIEW

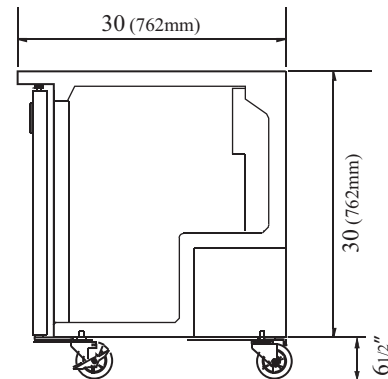

SIDE VIEW



■ Turbo Air : 800-627-0032 ■ GK : 800-500-3519
■ Warranty : 800-381-7770 ■ AC : 888-900-1002