



Follow the Leader™

Floral • Deli • Seafood • Meat • Bakery • Produce • Front End

INTRODUCING **THE UNISOURCE HEAVY DUTY** **MILANO ARTISAN™** **DECK OVEN SERIES**

Features:

- Modular fully insulated deck design
- Two or three pan wide capacity
- One to four decks in height
- Each deck independently operated
- Double glazed full width/height viewing windows
- Patented self contained high capacity steam system
- Single piece stone hearth on all decks with special glaze finish for easy cleaning
- Digital control panel features thermostat, bake and steam timers, 7-day auto on control, upper, lower and front heat controls, interior light
- Guaranteed to bake even!
- Stand w/locking casters
- Canopy w/950 cfm fan (No other hood needed)
- One year parts/labor warranty
- 24/7 nationwide service

Models:

- UNI-D02W-1 (single deck/two pans wide)
- UNI-D02W-2 (two decks/two pans wide)
- UNI-D02W-3 (three decks/two pans wide)
- UNI-D02W-4 (four decks/two pan wide)
- UNI-D03W-1 (single deck/three pans wide)
- UNI-D03W-2 (two decks/three pans wide)
- UNI-D03W-3 (three decks/three pans wide)
- UNI-D03W-4 (four decks/three pans wide)

Options:

- Pan slides under stand



**Unisource Milano Artisan Bread/Pastry Oven
with High Capacity Self Contained Steam System**





Follow the Leader™

INTRODUCING THE UNISOURCE HEAVY DUTY MILANO ARTISAN™ DECK OVEN SERIES

Width/Depth Dimensions

Description	2 Pan Wide	3 Pan Wide
A=Outside Width	55.7"	74.4"
B=Internal Chamber Width	37.3"	55.9"
C=Internal Chamber Depth	32.3"	32.3"
D=Outside Depth	49.6"	49.6"
With Oven Handle 53.5 Depth		

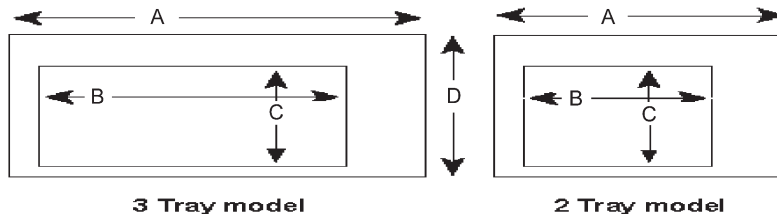

Height Dimensions

All ovens have a total height of 98.5" (includes Power fan installed) or 89" to top of oven

Description

A+F=Canopy w/Fan	17.5"			
A=Canopy Only	8"			
B=Top Cover	14" for 1 & 2 deck ovens	6" for 3 & 4 deck ovens		
C=Deck Height	13.8"			
D=Bottom Cove	4.1"			
E=Base w/Casters	1 Deck Oven 49.1"	2 Deck Oven 35.3"	3 Deck Oven 29.5"	4 Deck Oven 15.7"

F=Hood Connection

Note: to determine the exact location of all sections you must add all the appropriate sections to an oven. Example a four deck oven will have one each of items A+F, B, D and E plus four of item C (17.5+6+4.1+15.7+13.8+13.8+13.8+13.8=98.5")

Utility Connections

All dimensions correspond to the location on the oven sections and are not based upon dimensions from the floor or the ceiling due to the oven being available in multiple deck heights. When determining exact height from floor or ceiling of a specific oven refer to the overall height chart above.

A=Canopy exhaust. 6" O.D. round duct powered by factory supplied 950 cfm fan motor mounted on canopy. Duct must be installed 24" above roof line with windproof cap. Duct work supplied by others. Duct opening is located 23" from rear of oven and 27.5" (2 pan wide) or 37.2" (3 pan wide) from right hand side of oven.

B=Electrical connection for exhaust fan. Factory supplied 9' cord (no plug) located 8" on the rear right corner (facing front of oven) and 3" from top. 220/60/1 @ 6 amps.

C=Electrical connection for oven decks. Factory supplied 9' cord (no plug) located 3" on the right rear corner (facing front of oven) and 2 1/2" from top of deck. 220/60/3 @ 25 amps 9.1 kw (4 wire connection 3 phase plus ground).

NOTE: Each deck requires a separate electrical connection plus one canopy connection. Example: Four deck oven requires four electrical connections (one per deck) plus one canopy connection.

D=Water supply connection. 1/2" NPT hot or cold water supply @29-44 psi. located 10" on the right rear corner of the stand (facing front of oven) and 4" from the top of the stand. Only one water supply connection required per oven. No drain required. For proper operation of the steam system it is recommended that the water supply follow these specifications: Hardness of 2-4 grains per gallon, ph range of 7.0 to 8.0 and chloride concentration of 0-30 ppm. Consult your water treatment company for proper water filtration system.

E=Canopy overhang is 29".

Notes: A hard smooth level floor is required on which to position the oven and access for maintenance is located on the right hand side of the oven. It is recommended that a minimum gap of 12" be left on all sides of the oven to allow cooling also for moving the oven for servicing. Oven installation must be performed by factory authorized technicians and all utility connections must be performed by licensed contractors to meet all federal, state and local codes.

We reserve the right to change specifications and product design without notice. Such revisions do not entitle the buyer to corresponding changes, improvements, additions or replacements for previously purchased equipment.

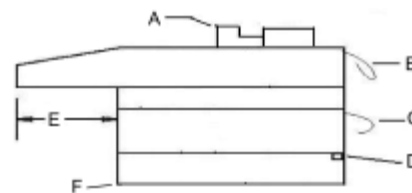
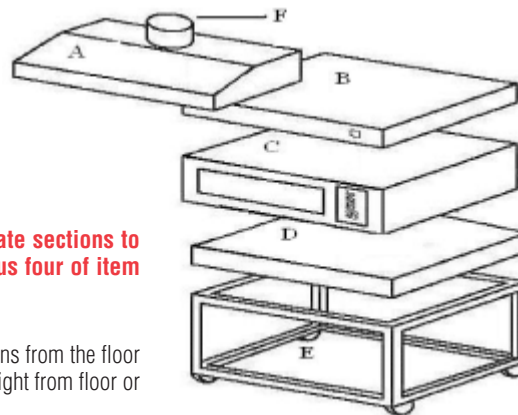

Phone: (888) 443-8782 • Fax: (516) 681-0845 • email: info@unisourcefoodequipment.com • www.unisourcefoodequipment.com
56 Rockland Drive, Jericho NY 11753