



CORNER DOUBLE (CB) (extended wrapper)

Chemical Sanitizing
Double Rack Corner Dishwasher

.96
Gallons Of Water
Per Rack!



**RIGHT FRONT DOOR
CONFIGURATION SHOWN**
AVAILABLE IN EITHER RIGHT OR
LEFT CONFIGURATION.

FEATURES:

- 80 racks / 320 covers per hour.
- Large 20-1/2" clearance for dishes.
- Economical to operate. Uses as little as .96 gallons of water per rack.
- All stainless steel construction assures long life and years of trouble free operation.
- Unique spray arm system features upper and lower stainless steel wash arms with reinforced end caps. Specially designed pull-pins allow wash arms to be easily removed for cleaning.
- Pump purging system improves results by eliminating soil and chemical carryover during rinse cycle.
- Top mounted controls include built-in chemical pumps and deliming system that assures proper chemical usage.
- Auto start/stop makes operation safe and easy.
- Built-in Poly Pro™ scrap accumulator *with all stainless steel drawer* prevents food soil from entering drain system.
- Water inlet comes with built-in strainer, prevents debris from clogging the water valve.
- Dishmachine comes with 2 dishracks.
- Stainless steel impeller offers extended life and service.
- Stainless steel scrap tray long lasting.

Available Options

- Solid/Powder Dual Bowl Dispenser
- The "TEMP-SURE" requires a separate 208-240v 3 phase 40 amp power supply.
- Sanitizer Alarm
- Alternative Cycle Times
- Alternative Voltages Available
- Stainless Steel Tables
- Stainless Steel Scrap Trap in lieu of Poly Pro
- Slant Shelf 21"X42"

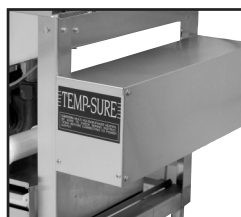

Optional Temp-Sure™ heater assures a continuous supply of 140°F hot water that guarantees excellent results.

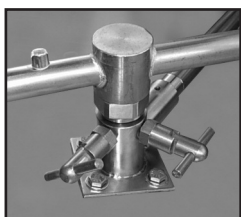

Unique pull-pin design allows wash arms to be easily removed for cleaning.



Sanitizer Alarm System is an audible alarm and warning light feature that gives a warning when sanitizer product is nearly empty.



Top mounted controls include built-in chemical pumps and deliming system that assures proper chemical usage.

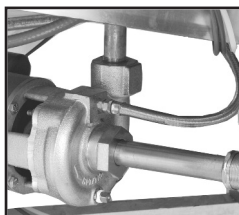

Pump purging system improves results by eliminating soil and chemical carryover during rinse cycle.

Energy
MIZER®



LISTED
COMMERCIAL
DISHWASHER
864T





**CORNER DOUBLE (CB)
ENERGY SAVER
(extended wrapper)**
Chemical Sanitizing
Double Rack Corner Dishwasher

WARNING: Plumbing connections must be made by a qualified service company who will comply with all available Federal, State, and Local Health, Plumbing and Safety codes.

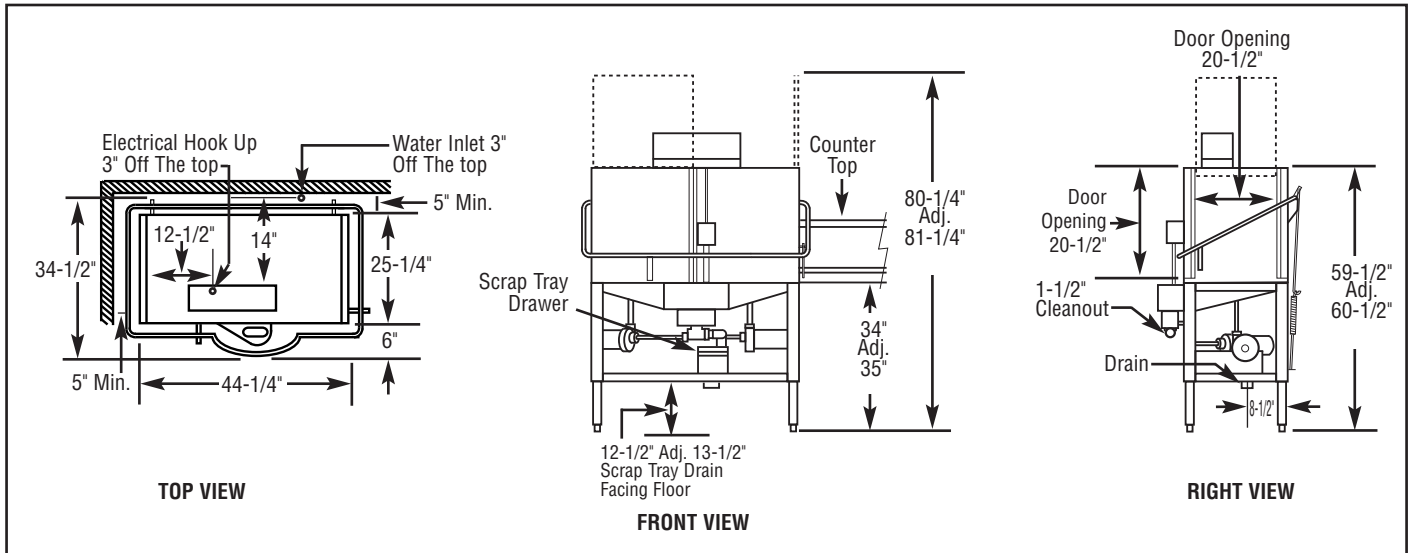

Specifications:

MODEL CB	USA	METRIC	USA	METRIC
OPERATING CAPACITY RACKS PER HOUR (NSF RATED)	80	80	WASH PUMP MOTORS HP (2)	1 1
OPERATING CYCLE WASH TIME-SEC RINSE TIME-SEC DWELL TIME-SEC TOTAL CYCLE TIME	45 30 15 90	45 30 15 90	DIMENSIONS DEPTH WIDTH HEIGHT STANDARD TABLE HEIGHT MAXIMUM CLEARANCE FOR DISHES	25-1/4" (64cm) 44-1/4" (112cm) 59-1/2"-60-1/2" (151.1-153.7cm) 34" (86cm) 20" (43cm)
WASH TANK CAPACITY	1.92 GAL.	(7.27 L)	STANDARD DISHRACK DIMENSIONS	2 2 19-3/4"X19-3/4" (50X50cm)
PUMP CAPACITY	104 GPM (2 Pumps)	(394 LPM)	ELECTRICAL RATING	VOLTS 115 AMPS 30
OPERATING TEMPERATURE REQUIRED RECOMMENDED	120°F 140°F	(49°C) (60°C)	SHIPPING WEIGHT APPROXIMATE	382# (173kg)
WATER CONSUMPTION PER RACK PER HOUR	.96 GAL. 118.4 GPH	(3.63 L) (446 LPH)		
WATER REQUIREMENTS WATER INLET DRAIN-I.P.S.	3/4" 2"	- -		

Summary Specifications: Model CB

CMA Energy Mizer model CB low temperature, chemical sanitizing commercial dishwasher meets NSF, UL, ETL and CSA sanitation and construction standards WITHOUT the use of BOOSTER or TANK HEATERS. The model CB is constructed entirely of stainless steel. Each unit automatically washes, rinses and sanitizes food service utensils in standard 19-3/4" x 19-3/4" racks. Unit comes standard with upper and lower stainless steel wash arms. The model CB incorporates a pump purging system that improves results by eliminating soil and chemical carryover during rinse cycle. **Note: This machine does not have built-in heaters, therefore produces no steam.**

