

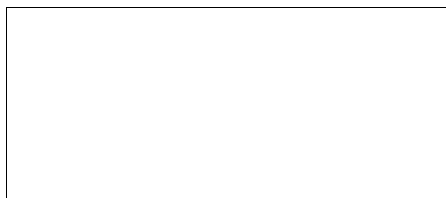

**R- MONTANA MULTIDECK
R-19**



**USER MANUAL
REFRIGERATING MULTIDECK**



Local Partner

The appliance's noise emission level does not exceed 70dB.

CONTENTS

1. Use.
2. General information.
3. Technical description.
4. Accessories.
5. Transport.
6. Operation.
7. Instruction Carel.
8. Electrical system.
9. Warranty repairs.
10. Figure 1: Refrigerating cabinet.
11. Figure 2: Refrigerating installation diagram.
12. Figure 3: Electrical wiring diagram.

1. USE.

The refrigerating display cabinet is designed for storage and attractive display of foodstuff, especially dairy produce and cured meats in lowered temperatures. The display cabinets designed for storage and display fruit and vegetable, and those designed for meat and cured meat products have different shelf construction. The cabinets have been given a positive opinion by the National institute of Hygiene.

2. GENERAL INFORMATION.

The refrigerating display cabinet is equipped with a lower display area and four under slung shelves. The cabinet can also be equipped, instead of shelves, with hook strips for cured meat products, or baskets for fruit and vegetables. After disassembling side covers the cabinets can be arranged in a display train. The temperature can be set within the range from +4°C to +10°C at the ambient temperature +25°C and 60% relative humidity.

3. TECHNICAL DESCRIPTION.

The cabinet's body is made from varnished steel sheet or zinc coated sheet, and placed on a base made from steel section. An energy-saving refrigerating unit with automatic controls is located in the lower part of the appliance. The FI/o, R-S/o, R-P/o and R-PS series, for instance R20/o, are adapted for installation of external refrigerating unit.

4. ACCESSORIES.

x	warranty card	1pc
x	instruction manual	1pc
x	condensate container	1pc
x	thermostat instruction manual	1pc

5. TRANSPORT.

The manufacturer ships the appliance fully assembled and marked with a rating plate. During the transportation the appliance must be secured from falling over and damage to glass and varnish coat.

6. OPERATION.

Positioning and installation.

The refrigerating display cabinet should operate in an uninsolated place where proper air circulation is ensured, away from sources of heat, in ambient temperature between +16°C and +25°C and relative humidity up to 60% .

Precise leveling of the display cabinet prevents the appliance from noisy operation and ensures proper efflux of water during defrosting.

NOTE:

- improper electrical wiring that the appliance is plugged to may be a cause of a fatal electric shock.
- maximum load on one shelf cannot exceed 15 kg.
- it is recommended to drain the condensate to a floor drain.
- distance of at least 20 cm between the display case and the wall should be maintained to allow the case to cool down completely.
- Non-observance of the manufacturer's recommendation will cause the display cases' anomalous operation, damage to the refrigerating unit, and loss of warranty.

Activation and operation of the appliance.

The appliance is turned on and off with a switch placed on the cabinet's body. After plugging the appliance in and turning it on leave it empty and allow to cool, which takes place when the first full cycle completes, that is when the refrigerating unit turns off automatically. It is only then that it can be filled with foodstuff and used fully. Lighting is turned on and off with lighting switch. The display cabinet is equipped with a roller shade that should be rolled down at night, which allows for better cooling and saving energy. The unit is equipped with an electronic thermostat allowing for adjusting temperature. In order to adjust the temperature in the display cabinet follow recommendations in the thermostat instruction manual. The condensate container must be emptied periodically. The refrigerating unit operates cyclically, it is controlled by a thermostat and depends on such factors as ambient temperature, quantity of foodstuff and degree of evaporator icing.

The display cabinet operates optimally at the ambient temperature between +16°C and +25°C.

Maintenance.

Current maintenance is carried out by the user through:

- periodic wash with warm water and non-detergent agents; do not use any sharp tools to clean the interior of the display cabinet or its casing.
- monitoring the amount of impurities in the condenser and cleaning it with a hard brush and a vacuum cleaner.

Condenser pollution causes overheating of the refrigerating compressor, which leads to its damage. In such a case rights to warranty repairs are lost. Please, unplug the appliance before all the above mentioned routine maintenance is performed. Remove the refrigerating units chamber guard before cleaning the condenser.

NOTE: THE CONDENSER SHOULD BE CLEANED EVERY TWO MONTHS

REMEMBER! (safe usage Principles)

- do not plug in the appliance to an unearthed socket,
- an authorized electrician should check the efficiency of neutral grounding
- all repairs and adjustments of the electrical and refrigerating system should be performed only by an authorized electrician,
- in case of defects like sparking, punch-through etc, the appliance should be immediately unplugged, and the defect should be eliminated by an authorized electrician,
- unplug the appliance before cleaning and defrosting,
- not fill up the display case before it cools down (reaches the proper low temperature),
- do not fill up the display case with warm products ,
- remember to empty the condensate container,
- plug off the appliance and remove the cover before replacing the fluorescent lamp.

When cleaning or washing the device interior and shelves, it is necessary to wear protective gloves and use an appropriate brush.

6. INSTRUCTON CAREL



Keyboard description

Information: short time pressing of each key will call out a message on the function currently active.

7 UP/ON OFF

During normal operation of the controller: pressing for a time exceeding 3 seconds will change the work mode of ON/OFF controller while setting the parameter value /TEMPERATURE/: the parameter value will be increased.

8 SET/MUTE

During normal controller operation: switches off the alarm sound signal; if held depressed for longer than 1 second, it will show the set point/TEMPERATURE/. While setting the parameter value /TEMPERATURE/: when depressed, the set parameter value will be entered.

9 DOWN/DEFROST

During normal controller operation: if depressed for a time over 3 seconds, the manual defrosting mode will be ON? OFF. While setting the parameter value /TEMPERATURE/: the parameter value will be decreased.



CHANGE TO THE REQUIRED TEMPERATURE:

- Keep the key SET /B/ depressed for longer than 1 second: the screen will show the current set point value /temperature/;
- The set point value can be changed with keys Up /7/ and DOWN /9/;
- When obtained the required set point value /temperature/, the change should be confirmed by pressing the key SET.

MANUAL DEFROSTING INPUT/OUTPUT FUNCTION

In order to switch on/ switch off the manual mode defrosting, press the key DEFROST I9I and keep it depressed for a time exceeding 3 seconds (Fig.1).

Table of signals and alerts.

In case an alert is activated, the controller will display an appropriate alert code in the screen, blinking alternatively with the current temperature value if the controller is provided with a sound signal to be activated and an auxiliary output AUX; then, both the signal and AUX output will be triggered ,

All alerts are provided with automatic reset (they are deactivated when the cause of alert has disappeared), except alert CHt - which is reset manually (switch off the controller with key Up or switch off the supply).

Pressing SET will mute the sound signal; the alert code and relay will remain switched on until the cause of alert has disappeared. The table below specifies alert codes with descriptions.

Table of alarms

Alert code	Sound signal and alert relay	Diode	Alert description	Reset	Alert activation	Easy	Easy comp act
E0	Active	ON	Error- control sensor 1	Auto.	-	v	v
E1	Not active	ON	Error-control sensor 2-defrosting	Auto.	D0=0/1/4; F0=1	v	v
E2	Not active	ON	Error- control sensor 3 condenser/product	Auto.	A4=10	v	-
IA	Active	ON	External alert	Auto.	A4=1+A7	v	-
dOr	Active	ON	Open door alert	Auto.	A4=7/8+A7	v	-
LO	Active	ON	Low temperature alert	Auto.	AL.; AD	v	v
HI	Active	ON	High temperature alert	Auto.	AH; Ad	v	v
EE	Not active	ON	Device alert	Impossible	-	v	v
EF	Not active	ON	Working parameter error	Auto.	-	v	v
Ed	Not active	ON	Defrosting complied, time out	Deactivate at next defrosting	dP;dt;d4;A8	v	v
dF	Not active	OFF	Defrosting in course	Auto.	d6=0	v	v
cht	Not active	ON	Pre-alert- dirty condenser	Auto.	A4=10	v	-
CHT	Active	ON	Alert- dirty condenser	Manual	A4=10	v	-
EtC	Not active	ON	Clock alert	Time set	With active time limits	v	-

7. ELECTRICAL SYSTEM

The power supply system should be made of a separate 230V 50Hz circuit. The wiring is made in protective system with a PE wire. Before plugging in and turning the appliance on please make sure that power supply conforms to the data on the refrigerating unit's rating plate. Ensure that proper protection **I=10A** is installed before the wall socket.

NOTE:

The appliance is equipped with a non-detachable power lead with a plug. The appliance should be placed in such a way that the plug is easily accessible. In case of damage to the power lead it should be replaced with an identical lead available at the manufacturer's or service representative's.

Electrical system diagram

8. WARRANTY REPAIRS.

The purchaser receives a Warranty cards signed by P.P.H.U COLD" General Partnership.

The warranty card contains information on rights and repairs.

Possible fault should be reported to the local dealer over the phone.

9. Figure 1. Refrigerating multideck

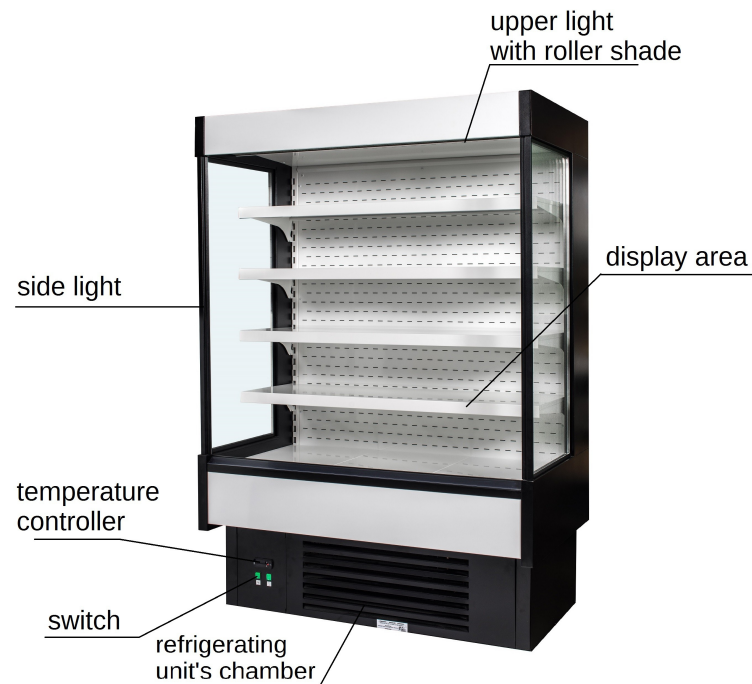

10. Figure 2. Electrical system diagram.

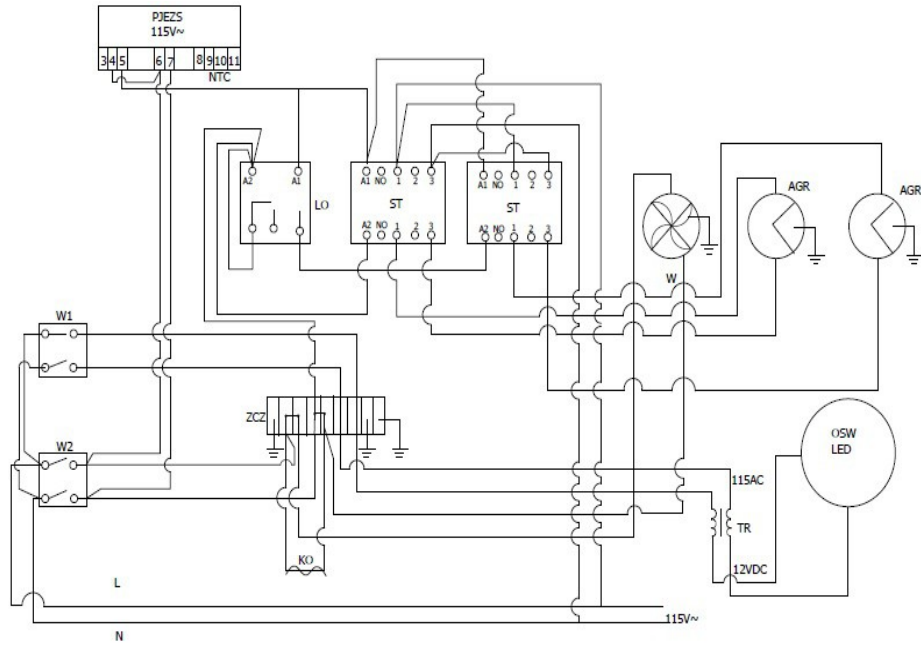

- **PJEZS**- temperature controller
- **AGR**- aggregate
- **TR**- transformer
- **W1**- lighting switch
- **W2**- aggregate switch
- **ST**- contractor
- **ZCZ**
- **LO**- unit start delayer
- **W**- evaporator diffuser
- **KO**- condensate heater

ALL PRODUCT INFORMATION HERE IN IS SUBJECT TO CHANGE WITHOUT NOTICE.

Within the technical progress, the manufacturer reserves the right to make changes in order to improve quality of the product. These changes may not be highlighted in the operation manual but the features of the described type remain unchanged.