

9810 - 9810.1

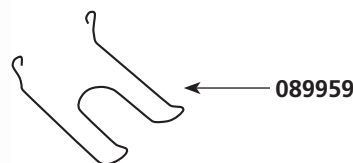
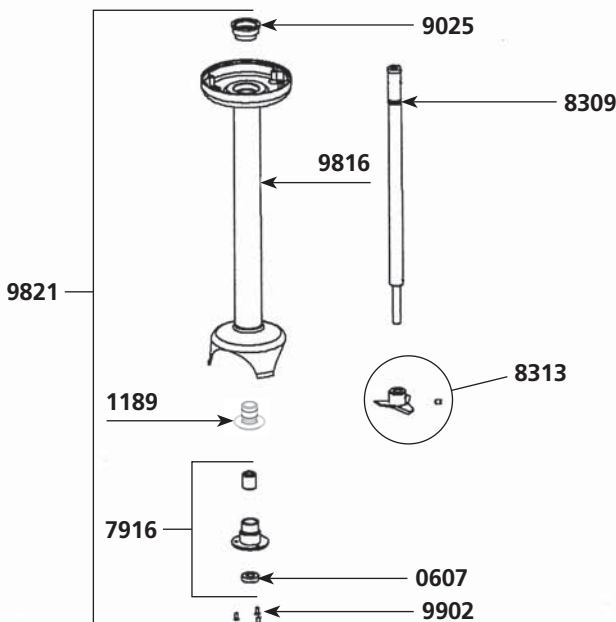
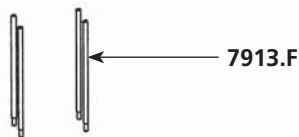
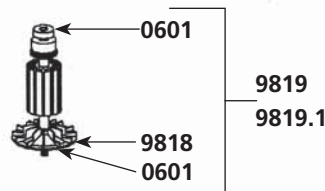
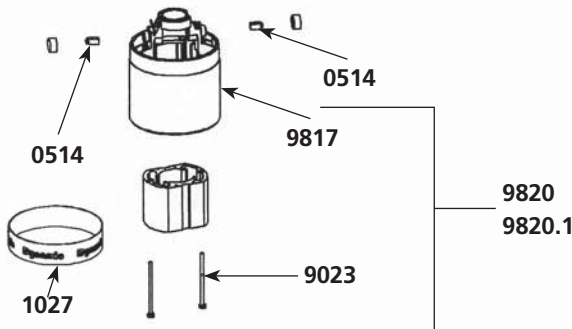
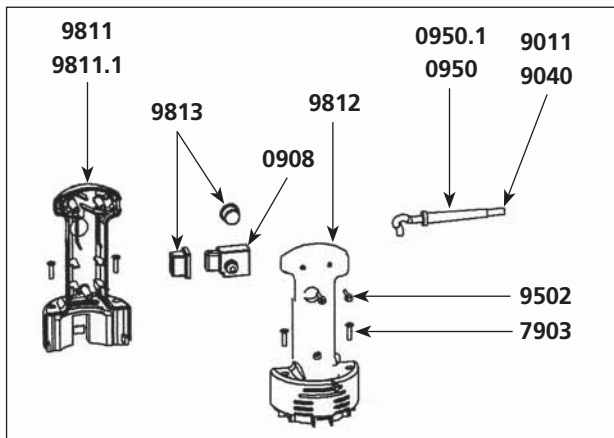

Parts list

Code List \$ Price

Code	List \$	Price
Motor brushes (2)	0514	15,31
Ball bearing	0601	15,31
Waterproof seal	0607	19,97
Squeezing washer	0726	2,15
Wall bracket	089959	22,46
Non-locking switch	0908	32,06
Strain relief 230 V	0950	2,68
Strain relief 115V	0950.1	2,68
Capacitor	0972.1	17,32
Warning label	1017	5,39
Dynamic label	1027	13,35
Label w/ serial number 230 V	1063	5,60
Label w/ serial number 115 V	1064	5,60
Lower bearing assembly support	1189	22,89
Speed variator (option) (230V)	1213	106,11
Speed variator (option) (115V)	1214	92,21
Spacer screws (4)	7903	4,96
Spacer rods (4)	7913.F	17,26
Lower ball bearing assembly	7916	37,10
Shaft	8309	80,25
Cutter blade w/screw	8313	40,54
Power cord 230 V	9011	23,76
Stator screws (2)	9023	4,04
Ball bearing sleeve	9025	4,68
Power cord 115 V	9040	29,74
Power cord (Australian)	9066	59,58
Power cord (UK)	9067	54,21
Handle screws (3)	9502	0,66
Complete handle 230 V	9810	71,64
Complete handle 115 V	9810.1	71,64
Lower half handle w/ label 230 V	9811	31,19
Lower half handle w/ label 115 V	9811.1	31,19
Upper half handle	9812	28,02
Switch protector (2)	9813	9,25
Motor & shaft housing + palier + bearing	9816	163,57
Upper motor casing (w/carbon brushes holders)	9817	47,75
Fan	9818	11,01
Rotor 230 V	9819	258,38
Rotor 115 V	9819.1	258,38
Stator 230 V (w/carter, carbon brushes holders)	9820	258,38
Stator 115 V (w/carter, carbon brushes holders)	9820.1	258,38
Complete foot assembly	9821	314,50
Shaft, lower ball bearing & cutter assembly	9836	135,51
Lower bearing screws (3)	9902	1,34