

Product Line	STANDARD GLAZERS	SPEC HG18-24C 04-2013
Model	HG18C, HG24C	

Belshaw's HG18C and HG24C glazers allow fast, uniform glazing of donuts, cinnamon rolls and other baked goods. These glazers conveniently glaze one full screen at a time with minimal waste.

All hand glazer models are movable on casters, include covers, and require little space. A bottom shelf provides storage for screens and a glaze bucket. A drain allows left over glaze to be poured out. Stainless steel construction and sound design facilitate cleaning and provide a durable product that will stand up to years of everyday use.

These glazers are supplied with a handheld "clamshell"-style glaze applicator. For glazers with a glaze applicator that is supported on rails, see models HG18EZ and HG24EZ.

Standard Features

- HG18C glazes 17" x 25" screens (43 x 63 cm) screens. Compatible with Belshaw Adamatic 618L and 718LCG-718LFG fryers, and all Donut Robots®.
- HG24C glazes 24" x 24" (61 x 61 cm) screens. Compatible with Belshaw Adamatic 624 and 724CG-724FG fryers.
- Capacity over 35 screens/hour in normal operation
- Listed by NSF for sanitation.
- Large kettle has curved interior corners for sanitation.
- 'Clamshell' opening to control flow of glaze from applicator.
- Applicator holds glaze to cover a basket of donuts at a single pass.
- Incorporates 1½" drain with valve to empty surplus glaze.
- Bottom shelf with storage for screens and a large glaze container.
- Drain tray has 3 settings to adjust angle of tilt. Raised stop prevents screens from sliding. Mountable on left or right side.
- Washable in rack washer or by hose down
- Stainless steel frame, kettle, applicator, and drain tray.
- 4" (100mm) heavy duty water-resistant casters (2 lockable)

Optional Items

- **Drain Tray.** Reduces floor spillage by allowing one screen of donuts to drip, while glazing another screen. (see below for Part Numbers)
- **Screens.** Glazers accommodate 2 standard screen sizes, as below

Model	Part# (Drain Tray)	Screen Size	Part# (Screen)
HG18EZ	HG18EZ-1002	17" x 25"	SL200-0004
HG24EZ	HG24EZ-0534	24" x 24"	HG24-0001



HG18C Standard Glazer (HG24C is 7" wider)
(Glazing screens are supplied separately)



HG18C Standard Glazer shown with supplied cover (HG24C is 7" wider)
(Glazing screens are supplied separately)



HG18C Glazer with Drain Tray



HG18C Glazer with Donuts



HG24C Glazer

90 Years of Quality Donut & Bakery Equipment

BELSHAW ADAMATIC BAKERY GROUP

814 44th St NW, Suite 103
Auburn, WA 98001 USA
PART OF ALI GROUP S.P.A.

CONTACT

800.578.2547 (USA/CANADA)
(+1)206.322.5474 Worldwide
service@belshaw.com

WEB

www.belshaw-adamatic.com
www.belshaw.com
www.adamatic.com

SPEC HG18-24C 04-2013

Product Line	STANDARD GLAZERS	SPEC
Model	HG18C, HG24C	HG18-24C 04-2013

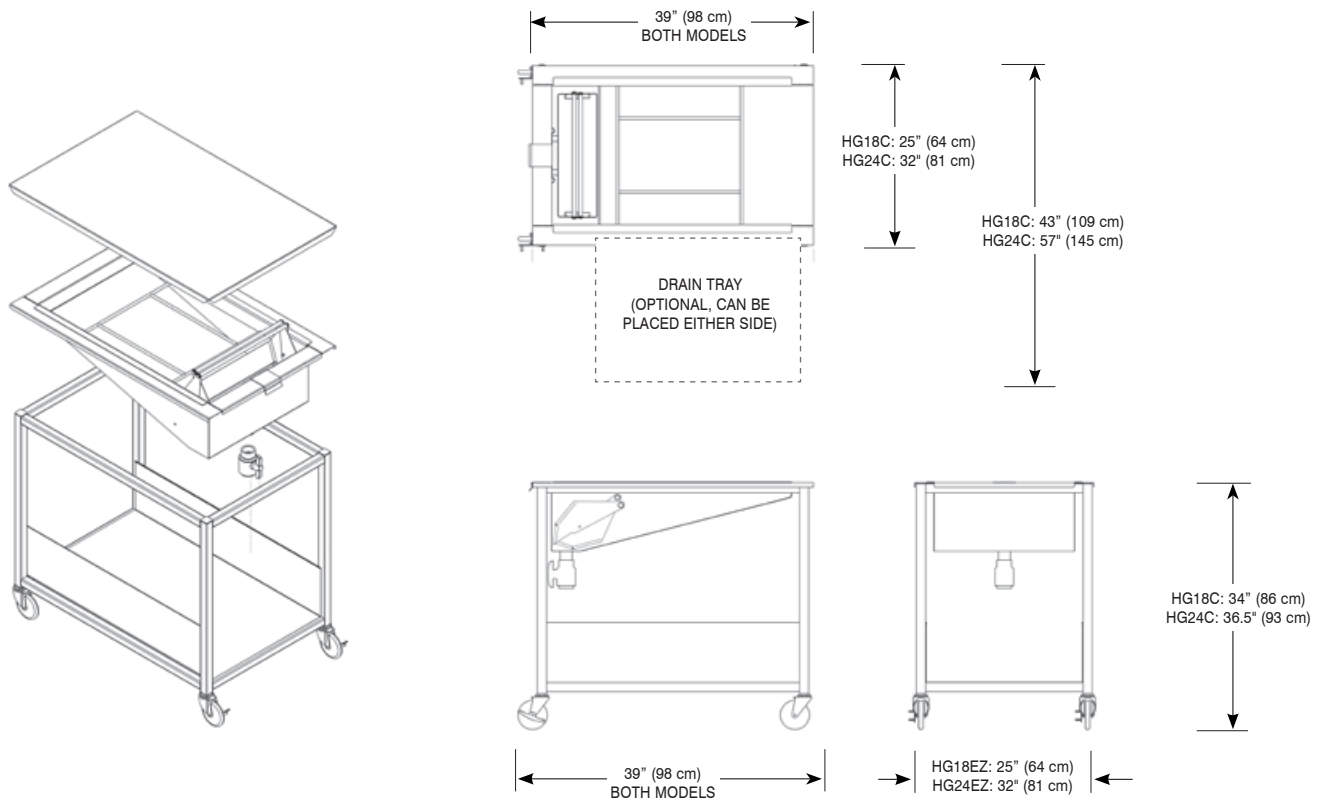

DIMENSIONS

		HG18C	HG24C
OVERALL DIMENSIONS <i>(with drain tray removed, or without drain tray)</i>	inches	25" W x 39" D x 34" H	32" W x 39" D x 36.5" H
	cm	64 x 98 x 86 cm	81 x 98 x 93 cm
SHIPPING DATA <i>(Approximate, shipped in carton on pallet or crate)</i>	inches	37" x 24" x 38"	40" x 48" x 54"
	cm	94 x 61 x 97 cm	102 x 122 x 137 cm
	lbs	96 lbs	156 lbs
	kg	44 kg	71 kg
FREIGHT CLASS		150	150



GLAZING SCREENS (Purchased separately)

		GLAZER MODEL	PART NUMBER (for GLAZING SCREENS)	SCREEN SIZE	APPROX. SHIPPING WEIGHT (Carton of 12 screens)
		HG18C	SL200-0004	17" x 25" (43 x 63 cm)	45 lbs (21 kg)
		HG24C	HG24-0001	24" x 24" (61 x 61 cm)	55 lbs (25 kg)
Sample Glazing Screen (made with high quality nickel plated steel)		FREIGHT CLASS: 70 (Screens only)			

90 Years of Quality Donut & Bakery Equipment

BELSHAW ADAMATIC BAKERY GROUP

814 44th St NW, Suite 103
Auburn, WA 98001 USA
PART OF ALI GROUP S.P.A.

CONTACT

800.578.2547 (USA/CANADA)
(+1)206.322.5474 Worldwide
service@belshaw.com

WEB

www.belshaw-adamatic.com
www.belshaw.com
www.adamatic.com

SPEC
HG18-24C
04-2013