



Ventless Kiosk

Insider

(Cabinet Only)

Operator's Manual

and

Technical Supplement

Belshaw Bros., Inc.
814 44th Street NW, Suite 103
Auburn, WA 98001 USA
Tel: (206) 322-5474
Fax: (206) 322-5425
Toll Free (US): 1-800-578-2547
E-mail: service@belshaw.com
www.belshaw.com





Insider

With Air Filtration Hood and Fire
Extinguishing System

Operator's Manual

Belshaw Bros., Inc.

814 44th Street NW, Suite 103

Auburn, WA 98001 USA

Phone: (206) 322-5474 • Fax: (206) 322-5425

E-mail: service@belshaw.com • <http://www.belshaw.com>

If you accept the machine from the shipping company, you are, in effect, saying that the machine is in good condition, and you must pay for the machine. Belshaw cannot pay for shipping damage, because the freight company has accepted the machine from Belshaw in good condition, and is responsible for its safe delivery. **For your protection,** inspect the machine to see that no parts are bent, scratched, or otherwise damaged. If any damage has occurred in shipping, file a freight claim with the shipping company immediately.

EQUIPMENT RECORD
Please provide the information below when you correspond with us about your machine.
Purchased by _____
Installed by _____
Date of Installation _____
Model number _____
Serial number _____

021208

MN-1852EN

Belshaw Bros., Inc.

814 44th Street NW, Suite 103

Auburn, WA 98001 USA

Phone: (206) 322-5474 • Fax: (206) 322-5425

E-mail: service@belshaw.com • <http://www.belshaw.com>

Contents

1	<i>Operation</i>	1
	Startup/Run	1
	Shutdown	1
	In Case of Fire	2
2	<i>Cleaning</i>	3
	Cleaning	3
	Hand Washing Instructions	4
	Automatic Dishwasher Instructions	4
	Cleaning Windows & Sliding Doors	5

Preface

The Insider is designed to hold and power the Belshaw Mark II, V, or IX Fryer and is provided with an air filtration and fire extinguishing system. It is not designed for any other purpose.

The operator must work safely at all times, read included manuals, and follow all instructions and warnings. A thorough understanding of how to install, maintain, and safely operate the Insider will prevent production delays and injuries.

To use the Insider safely, heed the following warnings and all other warnings that appear in this manual:

WARNING

THE CHARGING & SETUP OF THE PYRO-CHEM PLC-240/300 FIRE SUPPRESSION SYSTEM MUST BE DONE BY CERTIFIED PERSONNEL ON A REGULAR BASIS AND THE USE AND MAINTAINENCE OF THE INSIDER IS TO BE IN ACCORDANCE WITH NFPA-96.

- To avoid damaging the machine, never use force to assemble, disassemble, operate, clean, or maintain it.
- Be careful never to get shortening, water, or other materials on the floor. If anything does get spilled on the floor, mop it up immediately. Materials on the floor can cause people to slip or fall, resulting in serious injury or loss of life.
- To prevent unintentional startup and possible fire, unplug the machine if there is a local power outage. When the power is restored, it is safe to plug the machine in again.
- To avoid electrocution, make sure that all electrical cords are not frayed or cracked and that they do not pass through any water or shortening.
- Make sure that all electrical cords are routed so that no one will trip over them.
- The Insider is “**Intended for use in noncombustible surroundings only.**”

Startup/Run

1. Make sure all filters are properly installed and all doors are closed.
2. Check the fire suppression cylinder gauge for the proper range of pressure and the red control box indicator for the set mode.

CAUTION

Do not operate the Insider if gauge pressure is low or set mode is not displayed. The fire suppression system will not operate.

3. Plug the Mark II, V, or IX Fryer power cord into the receptacle labeled "Fryer" on the electrical box. The large hole in the counter top is for the power cord of the fryer.

CAUTION

Do not operate the Insider with polycarbonate windows or doors removed or open. Fire suppression system will cause hot shortening to splatter causing serious injury and burns.

4. Turn on the fryer, Insider and auxiliary circuit breakers.
5. Plug the Insider main power plug into the customer supplied power receptacle.
6. Push the green "Start" button to energize the unit. Hold the "Start" button in for a few seconds while the proper airflow is attained.
7. The system must be on to provide power to the air filtration system, overhead lights, auxiliary outlet, fryer and cutter. (See Mark

II, V, or IX Fryer manual for information on fryer and cutter operation).

8. After charging and setup by certified personnel, the fire suppression system is always operational.
9. **Note:** If manual operation of the fire suppression system is required, the system can be actuated by pulling the handle straight out. The manual actuator is located to the right of the red fire suppression cylinder.

Shutdown

1. Pushing the "Stop" button shuts off all power to the unit, including fryer.
2. Opening the hood doors, removing a filter or operation of the fire suppression system will shutdown the Insider.
3. The unit will not restart if the fire suppression system has been operated. Recharging and setup by certified personnel will be required.
4. After shutdown disconnect power and let shortening cool to 100° F/38° C before disassembling or cleaning fryer. Refer to Mark II, V, or IX manual for instructions.

WARNING

Electrical Shock Hazard. Have power off and disconnected at source before doing any cleaning or maintenance.

In Case of Fire

Fires can potentially start in the fryer, the hood, or the duct. In case of fire, it is important that you fully understand the operation of your fire suppression system.

1. Evacuate all personnel and customers from the fire area.
2. If your fire suppression system has not already automatically activated, you may activate it manually by pulling the handle on the silver manual pull station, located at the back of the Insider to the right of the red fire suppression cylinder.
3. Call the Fire Department.
4. Personnel trained in the proper operation of hand portable extinguishers may stand by if means of easy exit are available.

When the fire has been extinguished, call your local authorized Pyro-Chem distributor to recharge the system, after determining the cause of fire. Under no circumstances should cooking operations be attempted before qualified personnel re-instate the integrity of your fire suppression system.

Cleaning**WARNING**

Thoroughly clean and dry floor if shortening, water, or other materials are spilled. If spillage is not cleaned and dried there will be danger of serious injury or loss of life.

WARNING

Do not use flammable solvents or other flammable cleaning aids for cleaning.

WARNING

Do not apply cleaning chemicals on fusible links or other detection devices of the automatic fire suppression system.

Hood, cabinet, counter top, fans, ducts, and other surfaces should be cleaned to bare metal at **frequent intervals or a minimum of every 3 months**, before they become heavily contaminated with grease or oily sludge. They should be inspected at least once every month.

If a vent cleaning service is used, a certificate showing date of inspection or cleaning should be maintained on the premises.

A certified person acceptable to the authority having jurisdiction shall inspect the entire system.

IMPORTANT

A signed and dated log of maintenance must be kept on premises for use by authority having jurisdiction.

WARNING

Handle the air cleaner cell carefully to avoid damage.

The pre-filter, and grease filter should be cleaned daily. The air cleaner cell should be washed weekly. The doors on the hood provide access to the air cleaner cell and pre-filter (see Illustration A).

Replacement filters

<u>Qty.</u>	<u>Part No.</u>	<u>Description</u>
1	H200-002	Primary Grease Filter
1	I-0123	Pre-Filter
1	IN-0526	Air Cleaner Cell
1	I-0181	Air Baffle
2	I-0068	Carbon Filter

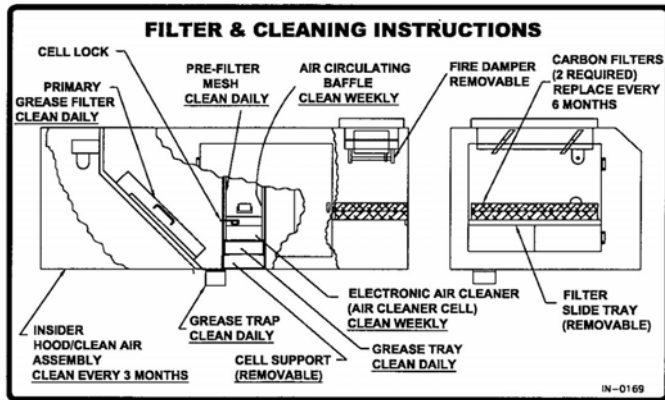

Illustration A

Note: See section 3, on page 20 for air cleaner cell maintenance and washing instructions.

Hand Washing Instructions

Note: Always wash the air cleaner cell first, then the pre-filters. This will help keep heavy lint on the pre-filter from getting caught in the cells.

Wash the cell and filters as follows:

1. Use a container large enough to hold the air cleaner cell, such as a laundry tub or trash container.
2. Dissolve about 3/4 cup of automatic dishwasher detergent in enough hot water to cover the cell. If the detergent doesn't dissolve readily, or forms a scum on the water, try another brand, or use softened water.
3. After the detergent has completely dissolved, place the cell in the container and let soak for 15-20 minutes. Agitate up and down a few times, and remove.
4. Next, wash the pre-filter and grease filter the same way. Empty and rinse the wash container.
5. Rinse the cell, pre-filters and grease filter with a hard spray of very hot water, rinse the tub clean, and then fill the tub with clean hot water and soak for 5 to 15 minutes. Rinse

until the water draining from the cell, pre-filter and grease filter no longer feels slippery.

Automatic Dishwasher Instructions

1. Put the air cleaner cell on the lower rack of the dishwasher with the airflow arrow pointing up. It may be necessary to remove the upper rack. Don't block water flow to the upper arm, if provided on your dishwasher.
2. If you are washing the pre-filter and grease filter with the cell, place them where they won't block the water from the electronic cell.
3. Using the detergent that works best for normal dishwashing, allow the dishwasher to run through the complete wash and rinse cycle. Do not use the dry cycle. To avoid burns, wear protective gloves when removing the cell, or let it cool first. Remember that water may be trapped in the tubes supporting the collector plates. Tip the cell so these tubes can drain.
4. Inspect the dishwasher. You may wish to rerun the wash and/ or rinse cycle with the dishwasher empty if you see dirt or residue from washing the cell. If dirt or residue seems excessive, wash the cell more often or try a different detergent.

WARNING

Allow the cell to cool or wear protective gloves to avoid burns. Hot water may accumulate in the tubes supporting the collector plates. Tip the cells so these tubes will drain.

5. Wipe the ionizer wires and red contact board with a clean cloth.
6. Reinstall the filters and air cleaner cell.

Note: A snapping sound may be heard when the cell is reinstalled after washing. This is caused

by arcing do to water remaining in the cell. This will cause no harm and the sound will quit when the cell has dried

Cleaning Windows & Sliding Doors

1. Use a mild liquid dishwashing soap and a soft cloth or sponge.
2. Dry with soft cloth.

WARNING
Polycarbonate will mark easily, be very careful while handling. DO NOT use any solvents or cleaning chemicals



Insider

With Air Filtration Hood and Fire
Extinguishing System

Technical Supplement

Belshaw Bros., Inc.

814 44th Street NW, Suite 103

Auburn, WA 98001 USA

Phone: (206) 322-5474 • Fax: (206) 322-5425

E-mail: service@belshaw.com • <http://www.belshaw.com>

If you accept the machine from the shipping company, you are, in effect, saying that the machine is in good condition, and you must pay for the machine. Belshaw cannot pay for shipping damage, because the freight company has accepted the machine from Belshaw in good condition, and is responsible for its safe delivery. **For your protection,** inspect the machine to see that no parts are bent, scratched, or otherwise damaged. If any damage has occurred in shipping, file a freight claim with the shipping company immediately.

To unpack the Insider and transport it to the workstation:

1. Use a forklift or a pallet jack to move the shipping crate to the workstation.
2. Remove the machine from the shipping crate, being careful not to lose or damage any of the parts.
3. Remove all packing materials from the machine.

EQUIPMENT RECORD

Please provide the information below when you correspond with us about your machine.

Purchased by _____

Installed by _____

Date of Installation _____

Model number _____

Serial number _____

021208

MN-1853EN

Belshaw Bros., Inc.

814 44th Street NW, Suite 103

Auburn, WA 98001 USA

Phone: (206) 322-5474 • Fax: (206) 322-5425

E-mail: service@belshaw.com • <http://www.belshaw.com>

Contents

1	<i>Installation</i>	1
	Unpacking the Insider	1
	Initial Cleaning	1
	Replacement Air	1
	Required Placement	1
	Insider Assembly	2
	Fire Suppression System	4
	Fire Damper System	4
	Arming the Fire Damper	5
2	<i>Maintenance</i>	6
	“Quick Check” Inspections	6
	Use and Maintenance	6
	Fire Suppression System	6
	Fire Damper System	13
	Carbon Filters	14
	Electronic Air Cleaner	14
3	<i>Troubleshooting</i>	15
	Troubleshooting	15
	1 Insider will not run	16
	2 Insider will not stay running	16
	3 Electronic Air Cleaner – Troublechart	18
	4 Electronic Air Cleaner Symptoms and Corrections	18
	5 Electronic Air Cleaner Electrical Problems	19
4	<i>Pyro Chem</i>	23
	In Case of Fire	24
5	<i>Appendix</i>	26
	Pyro Chem (Kitchen Knight) Owners Manual	Insert
	Parts List Drawing Insert Page	Insert

Preface

The Insider is designed to hold and power the Belshaw Mark II, V, or IX Fryer and is provided with an air filtration and fire extinguishing system. It is not designed for any other purpose.

The operator must work safely at all times, read included manuals, and follow all instructions and warnings. A thorough understanding of how to install, maintain, and safely operate the Insider will prevent production delays and injuries.

To use the Insider safely, heed the following warnings and all other warnings that appear in this manual:

WARNING

THE CHARGING & SETUP OF THE PYRO-CHEM PLC-240/300 FIRE SUPPRESSION SYSTEM MUST BE DONE BY CERTIFIED PERSONNEL ON A REGULAR BASIS AND THE USE AND MAINTAINENCE OF THE INSIDER IS TO BE IN ACCORDANCE WITH NFPA-96.

- To avoid damaging the machine, never use force to assemble, disassemble, operate, clean, or maintain it.
- Be careful never to get shortening, water, or other materials on the floor. If anything does get spilled on the floor, mop it up immediately. Materials on the floor can cause people to slip or fall, resulting in serious injury or loss of life.
- To prevent unintentional startup and possible fire, unplug the machine if there is a local power outage. When the power is restored, it is safe to plug the machine in again.
- To avoid electrocution, make sure that all electrical cords are not frayed or cracked and that they do not pass through any water or shortening.
- Make sure that all electrical cords are routed so that no one will trip over them.
- The Insider is “**Intended for use in noncombustible surroundings only.**”

Unpacking the Insider

Use a forklift to transport the shipping crate to the workstation.

- Break down the shipping crate.
- Remove the packing materials from the Insider, including foam, tape, brown paper, plastic, and white protective coating. Do not remove the plastic from the Plexiglas doors at this time.
- Inspect the machine to see that no parts are bent, scratched, or otherwise damaged. If any damage has occurred in shipping, file a freight claim with the shipping company immediately.
- Mail the attached warranty registration form within ten days of installation.
- Keep this manual for future reference. Put it where you know you can find it.

Initial Cleaning

Remove ***all*** the packing materials. Wipe the Insider with a soft, damp cloth. Dry these areas completely.

WARNING

To avoid electrocution or other injury, turn off the machine's main power before attempting any cleaning, disassembly, adjustment, or repair.

NOTICE

"IN CASE OF FIRE"

Instructions for manually operating the fire suppression system are posted conspicuously on the insider hood and should be reviewed periodically with employees by the management. Only persons properly trained and qualified to install the specific system being provided must make installation and charging of systems. The installer must certify to the authority having jurisdiction that the installation is in complete agreement with the terms of the listing and the manufacture instructions and/or approved design.

WARNING

Always dry floor after washing equipment

Replacement Air

Replacement air quantity must be adequate to prevent negative pressures in the commercial cooking area(s) from exceeding 0.02-inch water column (4.98 Pa).

Required Placement

When the Mark II, V, or IX Fryer is installed in the insider cabinet. It must be located on the lineup pins to provide the proper placement.

WARNING

The Insider is “intended for use in noncombustible surroundings only.”

WARNING

Electrical shock hazard. Have power off and disconnected at source before making connections.

Insider Assembly

WARNING

DO NOT connect the insider to power until all assembly has been completed and the fire suppression system has been set up and checked by certified personnel.

Note: Some of the following items may be shipped installed. See illustrations A & B for Insider assembly.

1. Unpack and setup the Mark II, V, or IX Fryer per instructions in the operator’s manual.
2. Install the Insider cabinet legs to the threaded holes in the bottom four corners of the frame. Level the cabinet by screwing the four legs all the way in and then unscrewing individual legs as required to level the counter top.
- 2a. The optional casters can be used in place of the legs and are installed in the threaded holes in the bottom four corners of the frame. Install a flat washer between the caster and frame. Use the 7/16” hex nut beneath the lower wheel raceway to install.

3. Lift the Mark II, V, or IX Fryer assembly on the cabinet top and place over the locating pins. This properly locates the fryer under the fire suppression nozzles.
4. Remove the protective paper and the vinyl from the sheet metal, windows and doors.
5. Install the lower back door track by dropping it over the two locking tabs in the lower door opening.
6. Install the poly-carbonate windows by inserting them in the upper channel and sliding them over the two locking pins.
7. The two back sliding doors are installed by lifting them into the door runners.
8. Install the grease trap under the hood and install the primary grease filter by turning sideways and up through the large opening under the hood. Locate the filter between the angle guides and against the interlock switch.
9. Install the cell support assembly into the hood compartment located by the back door hinge side. Slide it straight in between the two baffles and then drop straight down to the hood bottom. It will not fit if installed at an angle. The grease tray slides into the cell support.
10. The air cleaner cell will slide into the hood on top of the cell support. Slide the cell straight into the opening so as not to damage the cell top contact tab.

CAUTION

Installing the air cleaner cell at an angle may damage the cells electrical contact.

DO NOT force the cell into place.

1. INSTALLATION

INSIDER ASSEMBLY
ILLUSTRATION A

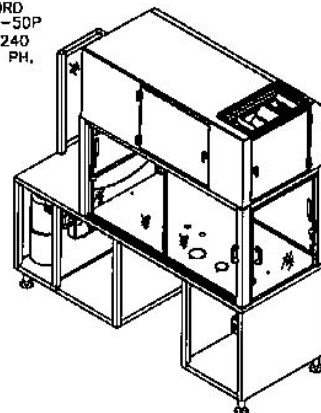
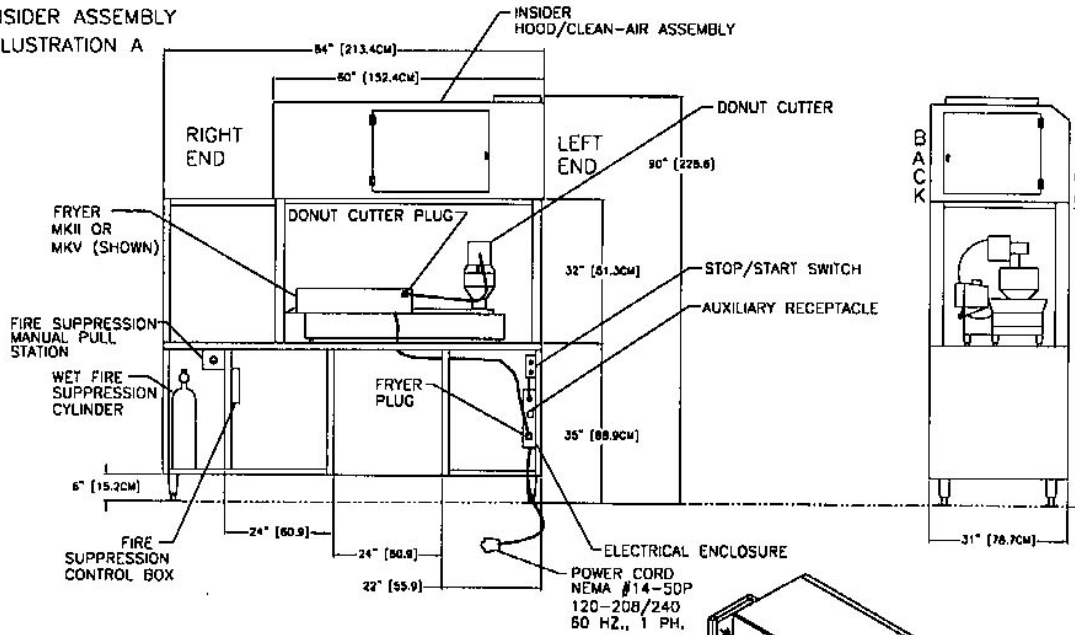

1. INSTALLATION

HOOD ASSEMBLY
ILLUSTRATION B

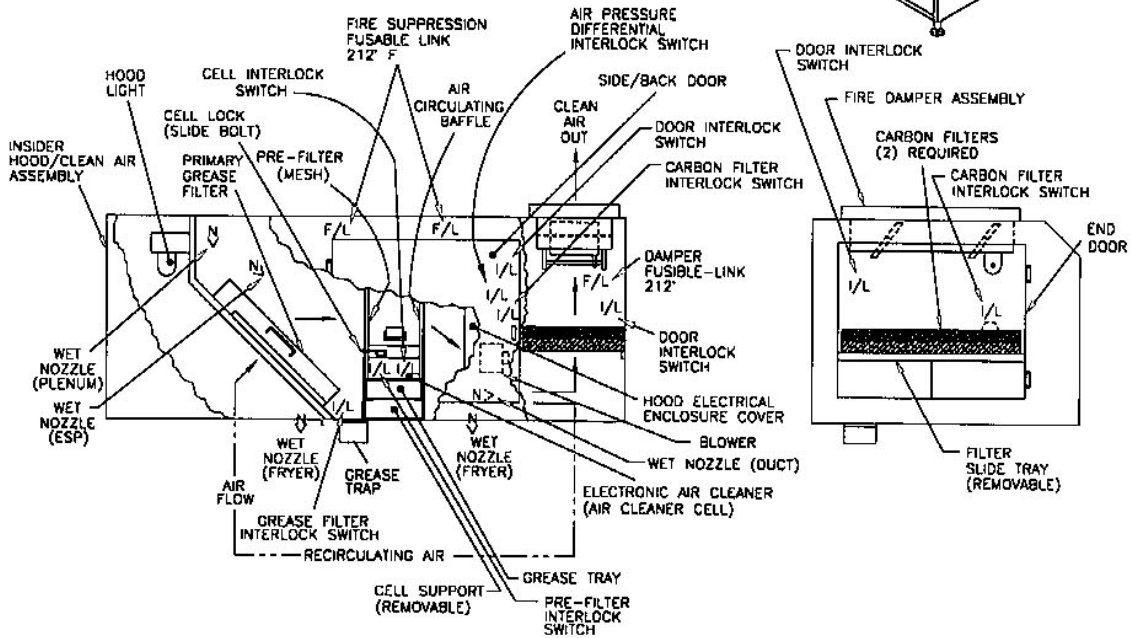

11. Slide the aluminum mesh pre-filter all the way into the groove on the left side of the cell, then push the cell all the way back against the angle stop and lock into place with the slidebolt. The slidebolt will hold the pre-filter in place and hold the cell and pre-filter against the inside interlock switches. Make sure the slidebolt is engaged through the small locating hole in the left side compartment.
12. Slide the air-circulating baffle all the way into the cell's right side groove.
13. Install the damper sleeve assembly by dropping it into the large hole on the top of the hood. Install with the fuse link pivot assembly towards the hinge side.

CAUTION

Installing damper the wrong way will damage the interlock switch.

14. Place two carbon filters into the filter slide tray and install through the end door on top of the support guides. The tray must be centered in the door opening, before opening the door.

CAUTION

Failure to center the tray may result in damage to tray and door.

15. Make sure the top carbon filter is in place and pushing against the inside interlock switch. There is a 1" diameter disc that pushes against the top filter. The disc and switch are adjustable if required to make the interlock function. Shutting the door pushes the top filter against the interlock switch.

WARNING

The Insider will not run with only one carbon filter. All the filters and door interlocks must be made before the Insider will start.

16. The system is now ready for the certified fire suppression service personnel to finish the installation procedure, including arming the fire damper.

Fire Suppression System

WARNING

THE CHARGING & SETUP OF THE PYRO-CHEM PLC-240/300 FIRE SUPPRESSION SYSTEM MUST BE DONE BY CERTIFIED PERSONNEL ON A REGULAR BASIS AND THE USE AND MAINTAINENCE OF THE INSIDER IS TO BE IN ACCORDANCE WITH NFPA-96.

Note: The fusible links used in the INSIDER are 212° F fusible links.

THE FIRE SUPPRESSION SYSTEM IS SHIPPED INACTIVE. The system must be armed before using. Removing the red control head internal safety pin and installing the CO2 cartridge is required to arm the fire suppression system.

WARNING

A customer provided hand portable fire extinguisher is required on the premises per NFPA 96 7-10.

Fire Damper System

FD-1300 Dynamic rated multi-blade fire damper
UL-555 1-1/2hr, File No. R11172.

The unit must be armed before using the insider.

Note: the fusible link used in the damper is 212°F.

Arming the Fire Damper

The damper is not functional until the safety pin is removed. A streamer is attached to the safety pin for identification. Remove the safety pin to arm the damper release mechanism as shown in Illustration C.

DANGER

To avoid causing death or serious bodily harm to building occupants, follow this step carefully. Removing the safety pin allows the damper blades to close completely to preserve the integrity of the fire barrier.

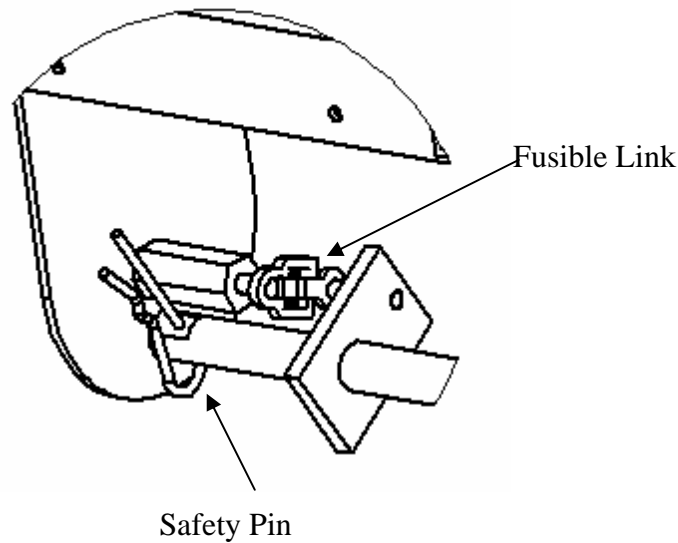

Illustration C

“Quick Check” Inspections

Inspection shall be conducted on a **monthly basis** by the owner, in accordance with the manufacturer’s installation and maintenance manual. As a minimum, the “quick check” or inspection shall include verification of the following:

The fire suppression system is in its proper location.

The manual actuators are unobstructed.

The maintenance tag or certification is in place.

No obvious physical damage or condition exists that might prevent operation.

The pressure gauge is in operable range.

The nozzle blowoff caps are intact and undamaged.

The hood, duct, and protected cooking appliances have not been replaced, modified, or relocated.

If any deficiencies are found, appropriate corrective action shall be taken immediately.

Personnel making inspections shall keep records for those fire suppression system that was found to require corrective actions.

At least monthly, the date the inspection is performed and the initials of the person performing the inspection shall be recorded.

The records shall be retained for the period between the semiannual maintenance inspections.

Use and Maintenance

All filters shall be cleaned or replaced in accordance with the manufacturer’s instructions. The grease filter and pre-filter should be cleaned

daily. The carbon filters should be replaced a minimum of every six (6) months.

The air cleaner cell shall be cleaned a minimum of **once per week** following manufacturers cleaning instructions.

The entire hood plenum and the blower section shall be cleaned a minimum of **once every three (3) months**.

Inspection and testing of the total operation and all safety interlocks in accordance with the manufacturers instructions shall be performed by qualified service personnel a minimum of **once every six (6) months** or more frequently if required.

A signed and dated log of maintenance as performed in accordance with above shall be available on the premises for use by the authority having jurisdiction.

Fire Suppression System

WARNING

THE CHARGING & SETUP OF THE PYRO-CHEM PLC-240/300 FIRE SUPPRESSION SYSTEM MUST BE DONE BY CERTIFIED PERSONNEL ON A REGULAR BASIS AND THE USE AND MAINTAINENCE OF THE INSIDER IS TO BE IN ACCORDANCE WITH NFPA-96.

Fusible links and nozzle caps must be replaced at **least annually** or more frequently if necessary to ensure proper operation of the system. Fusible links and all other detection devices must be serviced or replaced in accordance with the manufacturer’s recommendations.

For maintenance requirements read, the Pyro Chem fire suppression system inserts that are included in this manual.

Note: See section 1, page 3, Illustration A & B for component locations.

a) Daily Maintenance

1. Visually inspecting the red fire suppression control head assembly, for set mode display and pressure gauge to make sure the system pressure is within proper range.
2. Visually inspecting the system detection lines to make sure that the fusible links are operational.
3. Inspecting all nozzles, keeping them free from grease and assuring that all blow-off covers are in place.
4. Determining that easy access to the manual pull station can be made for manual activation.
5. Assuring that good housekeeping practices have been maintained to eliminate potential fire hazards.
6. Visually inspect the fire damper and fusible link for damage and operational readiness.

At this time, it is also good practice to visually inspect all premises hand portable fire extinguishers to verify good working condition.

b) Regular System Maintenance

To ensure the proper operation of the system, regular inspection and maintenance must be performed by certified personnel and on a **semi-annual** basis, and after every periodic hood and duct cleaning (whichever occurs more frequently).

The authorized distributor must be consulted after the system is discharged.

For six (6) month maintenance, annual maintenance and hydrostatic testing see the Pyro-Chem insert "System Maintenance".

Storage

Recharging supplies of wet chemical shall be stored in the original closed shipping container supplied by the manufacturer. These containers shall not be opened until the system is recharged.

Wet chemical supplies shall be maintained within the manufacturers recommended storage temperature range.

Maintenance

A trained person who has undergone the instructions and certification necessary to perform the maintenance and recharge service reliably and has the applicable manufacturers installation and maintenance manual and service bulletins shall service the wet chemical fire extinguishing system six (6) months apart as outlined below.

At least semiannually, maintenance shall be conducted in accordance with the manufacturers installation and maintenance manual. As a minimum, such maintenance shall include the following:

1. An examination of all detectors, the expellant gas container, releasing devices, piping, hose assemblies, nozzles, interlocks, the fire suppression cylinder and gauge pressure, and all auxiliary equipment.
2. Verification that the agent distribution piping is not obstructed.
3. Where semiannual maintenance of any wet fire suppression cylinder or system components reveals conditions such as, but not limited to, corrosion or pitting, structural damage or fire damage; or repairs by soldering, welding, or brazing; the affected part(s) shall be replaced or hydrostatically tested in accordance with the recommendations of the manufacturer. The hydrostatic testing of wet chemical containers shall follow the applicable procedures as outlined below.
4. The wet fire suppression systems shall be tested, which shall include the operation of the control head interlock mechanism and

switch, and releasing devices, including manual pull station and other associated equipment. A discharge of the wet chemical normally is not part of this test.

5. Where the maintenance of the system reveals defective parts that could cause an impairment of failure of proper operation of the system, the affected parts shall be replaced or repaired in accordance with the manufacturer's recommendations.
6. The maintenance report, with recommendations, if any, shall be filed with the owner or with the designated party responsible for the system.
7. Each wet chemical system shall have a tag or label securely attached, indicating the month and year the maintenance is performed and identifying the person performing the service. Only the current tag or label shall remain in place.

Fixed temperature-sensing elements of the fusible metal alloy type shall be replaced at least annually from the date of installation. They shall be destroyed or removed.

The year of manufacture and the date of installation of the fixed temperature-sensing element shall be marked on the system inspection tag. The tag shall be signed or initialed by the installer.

Recharging

All extinguishing systems shall be recharged after use or as indicated by an inspection or maintenance procedure.

Systems shall be recharged in accordance with the manufacturer's installation and maintenance manual.

Hydrostatic Testing

The following parts of wet chemical extinguishing systems shall be subjected to a hydrostatic pressure test at intervals not exceeding 12 years:

1. Wet fire suppression cylinder

2. Auxiliary pressure container

Exceptions:

1. Auxiliary pressure containers not exceeding 2-in. (0.05-m) outside diameter and less than 2 ft (0.6-m) in length.
2. Auxiliary pressure containers bearing the DOT ":3E" marking.

Wet fire suppression cylinder and auxiliary pressure container, shall be subjected to a hydrostatic test pressure equal to the marked factory test pressure or the test pressure specified by the manufacturer. No leakage or rupture shall be permitted. The test procedure shall be in accordance with the manufactures' detailed written hydrostatic test instructions.

Exception:

Containers bearing DOT or TC markings shall be tested or replaced in accordance with the appropriate DOT or TC requirements.

Wet chemicals removed from the containers prior to hydrostatic testing shall be discarded.

To protect the hazard during hydrostatic testing, if there is no connected reserve, alternate protection acceptable to the authority having jurisdiction shall be provided.

c) Pipe and Nozzle Installation

All pipe ends shall be thoroughly reamed after cutting and all oil and foreign matter removed from the pipe. It is recommended that the following procedures be followed:

1. Disconnect and remove discharge piping from the inside.
2. Make certain that all threaded ends and pipe are clean and the pipe is free of foreign matter and oil.
3. Apply Teflon tape on threaded ends. Start at the second mail thread, wrapping the tape clockwise around the threads, away from the pipe opening.
4. Do not over tighten, but be sure the pipe is snug. Do not back-off sections of pipe to make them fit better.

CAUTION

Do not apply Teflon tape to cover or overlap the pipe opening, as the pipe and nozzles could become blocked and prevent the proper flow of agent. Do not use thread sealant or pipe joint compound.

All piping shall be securely fastened to pipe hangers. A union is installed in the discharge piping close to the cylinder valve, to permit disconnection and removal for inspection and service. Dry air or nitrogen should be blown through the discharge piping to remove chips and other debris prior to installation of nozzles.

Nozzles shall be installed in accordance with the limitations described in this manual. Blowoff caps are provided for each nozzle. These will prevent dirt and grease from clogging the nozzle.

d) Fusible Link Detector Installation

Fusible links are always used in conjunction with the Model NMCH Mechanical Control Head.

After mounting the cylinder and control head, the fusible link line can be installed. The first step to installing the fusible link line is to install the detector bracket(s). These brackets must be installed in the plenum area of the ventilation hood over all protected Mark II, V, or IX Fryer and in each duct.

Note: Only FL-212 Fusible Links can be used.

Connect the fusible link brackets together using 1/2" conduit and the conduit connectors supplied in the detector kit (Model FLK-1/1A). A Pyro-Chem corner pulley must be used whenever a change in conduit direction is necessary. The conduit is connected to the control head through a knockout in the upper left-side corner.

In general, fusible links centered in the detector brackets are connected in series using 1/16" diameter stainless steel cable. The spring plate in the control head maintains tension on this series of fusible links.

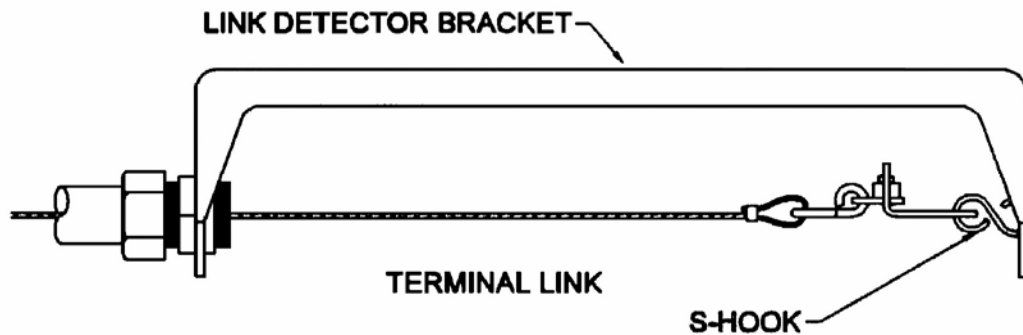

Illustration E

Terminal Link Installation

If the tension is released for any reason (i.e., a fusible link separates), the control head will operate and actuate the system. Maximum limitations for the fusible link detection line are as follows:

Fusible links can be installed with or without fusible link hangers.

1. Fusible Link Installation Without Hangers

Begin installing links at the terminal bracket. The link is connected to the far side of the terminal bracket using an “S” hook. The “S” hook must be crimped closed after the link is installed. A tight loop is then made in the cable and secured by the crimp provided. This loop is connected to the other side of the terminal link (see Illustration E) and the cable fed through the conduit to the next bracket.

After the last link in the series is connected, the cable should be fed through the conduit back to the control head. Thread the cable through the hole in the fusible link ratchet wheel. The line must then be crimped, and the crimp positioned inside the center of the ratchet wheel.

NOTE
<p>Crimps must always be used in conjunction with two (2) cable lengths. Loops are the accepted method of connecting the cable to mechanical components. The crimp must never be used on a single cable.</p>

The fusible link line can now be put into a set position by applying tension to the fusible link line. This is accomplished by using 3/4” socket on the fusible link line ratchet wheel. The ratchet wheel will be ratcheted in a clockwise direction until the spring plate makes contact with the top of the control head box. The fusible link line is now in a set position.

See Illustration F

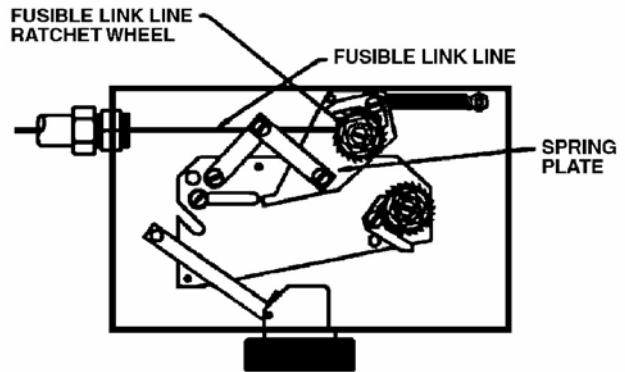

Illustration F
Fusible Line Link Termination

2. Fusible Link Installation Using Model FLH-1 Fusible Link Hangers

Beginning at the control head feed the stainless steel cable through the conduit and brackets to the terminal bracket in one continuous length. Allow approximately two and one half (2.5) inches of slack at each bracket for the installation of the Fusible Link Hangers. At the terminal link, a tight loop is made in the cable and secured by the crimp provided. The cable is attached to the far side of the terminal bracket using an “S” hook. The “S” hook must be crimped closed after the cable is installed. See Illustration G.

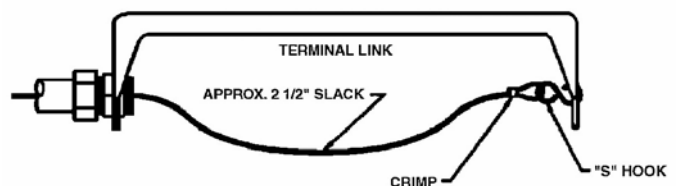

Illustration G
Terminal Bracket Connection

Begin installing the Fusible Link Hangers at the terminal bracket and work toward the control head. Loop the cable through the oval opening in the hanger and hook the fusible link on the loop. See Illustration H

Note: Only FL-212 Fusible Links can be used.

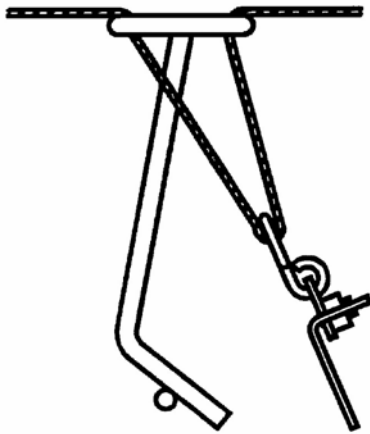

Illustration H
Fusible Link Connection

Hook the bottom of the link onto the bottom leg of the hanger. See Illustration I

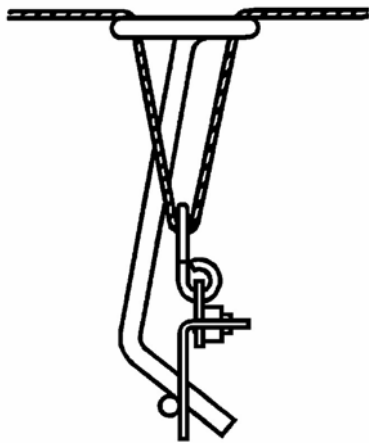

Illustration I
Fusible Link/Hanger Connection

Center the hanger/link in the fusible link bracket by sliding it along the link line. This is easily accomplished before any tension is applied to the link line. Repeat this procedure for all fusible links.

After the last hanger/link in the series is connected, the cable should be fed through the hole in the fusible link ratchet wheel. The line must then be crimped, and the crimp positioned inside the center of the ratchet wheel.

NOTE

Crimps must always be used in conjunction with two (2) cable lengths. Loops are the accepted method of connecting the cable to mechanical components. The crimp must never be used on a single cable.

The fusible link line can now be put into a set position by applying tension to the fusible link line. This is accomplished by using a 3/4" socket on the fusible link line ratchet wheel. The ratchet wheel will be ratcheted in a clockwise direction until the spring plate makes contact with the top of the control head box. The fusible link line is now in a set position. See Illustration F. Check to ensure that the fusible link hanger(s) remain centered in the bracket after the fusible link line is set. See Illustration J.

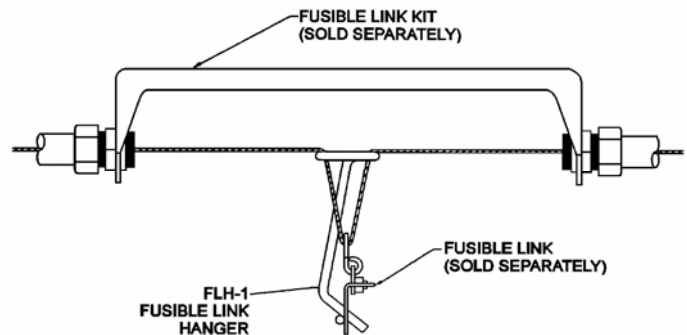

Illustration J
Fusible Link/Hanger In Set Position

e) Setting the Control Head **Model NMCH Mechanical Control Head**

Once the fusible link line is set, the control head can be placed in the set position. To set the control head, the slide plate is moved from right to left, ensuring the bolt extending from the cam arm is in the slot provided in the slide plate. Continue moving the slide plate to the left until the latching arm is in the locked position. Insert the pull pin into the hole in the slide plate above the latching arm. This will lock the control head

in the set position, eliminating accidental actuation during the rest of the installation procedure. See Illustration K

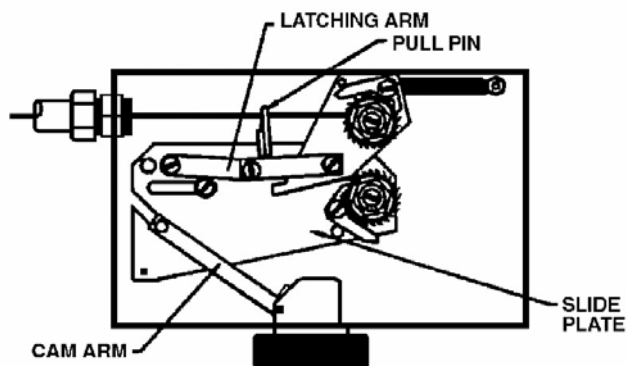

Illustration K
Miniature Switch Installation

f) Remote Pull Station Installation

The model RPS-M Remote Mechanical Pull Station is used for remote mechanical actuation of all system releasing devices. It is to be located near an exit in the path of egress from the hazard area no more than five feet above the floor.

NOTE

A Model RPS-M Remote Mechanical Pull Station must be used for manual activation of a Model EN-MCU or a Model NMCH releasing device.

The Pull Station can be surface mounted or flush mounted. For flush mounting a RACO #232, 4” deep electrical box or equivalent must be used (dealer supplied). It is connected to the releasing device using 3/64” or 1/16” diameter stainless steel cable. The cable enters the pull station box through the center hole in the bottom, top, either side, or the center back hole. The cable enters the control head through the top center knockout. The cable must be enclosed in 1/2” conduit with a Pyro-Chem corner pulley at each change in conduit direction.

After mounting the pull station box and conduit, feed the stainless steel cable from the releasing

device, through the conduit, and into the pull station box. Feed the cable through the bushing and through the hole provided in the pull handle. Loop the cable through the pull handle and secure it with the crimp provided. See Illustration L.

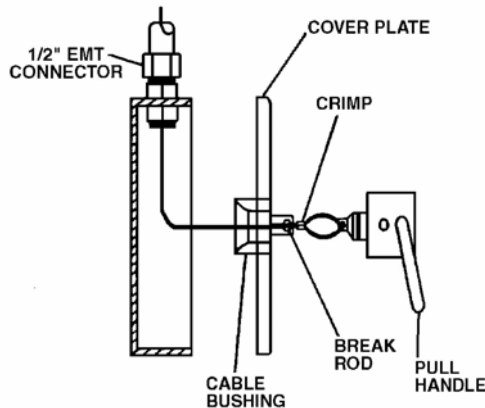

Illustration L

Model RPS-M Remote Pull Station Installation.

g) System Checkout After Installation

Model NMCH Mechanical Control Head

Before putting the system into service, all components must be checked for proper operation. During this checkout, assure that the carbon dioxide pilot cartridge is not installed in the control head actuator. Remove the pull pin from the hole in the slide plate.

To check satisfactory operation of the control head, cut the terminal link or the “S” hook holding the link. This will relieve all tension on the fusible link line and operate the control head. The slide plate will have moved fully to the right. Any auxiliary equipment connected to the dry contacts of the Miniature Switch in the control head will have operated.

If any of these events fail to occur, the problem must be investigated and repaired.

Repair the terminal link and put the fusible link line back into the set position. This is accomplished by using a 5/8” socket on the fusible link line ratchet wheel. The ratchet wheel will be ratcheted in a clockwise direction until the spring plate makes contact with the top of the control head box.

Once the fusible link line is set, the control head can be placed in the set position. To set the control head, the slide plate is moved from right to left, ensuring the bolt extending from the cam arm is in the slot provided in the slide plate. Continue moving the slide plate to the left until the latching arm is in the locked position.

Once the control head is set, pull the pull handle on the remote pull station to assure that the control head operates. If the control head operates normally, the control head can be reset as described above.

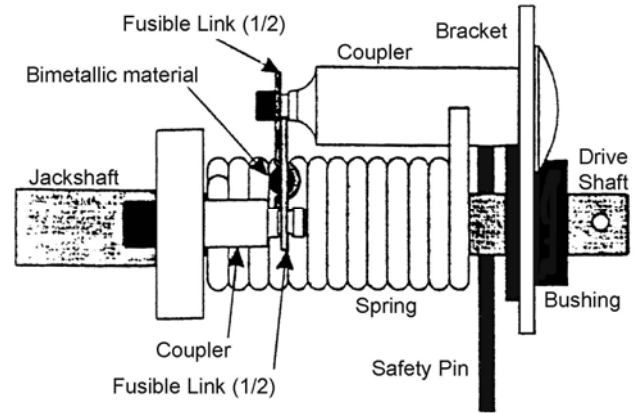

Illustration M
Fusible Link Location

If the fusible link is not present or there are any signs of damage during the inspection:

CAUTION

Before screwing the carbon dioxide pilot cartridge into the actuator, ensure that the actuator has a Teflon O-ring installed.

Using a felt-tipped marker, write the date of installation in the gray area of the carbon dioxide pilot cartridge. Screw the cartridge into the control head actuator until hand-tight. Never use a wrench to tighten the cartridge into the actuator.

Remove the pull pin from the hole in the slide plate and install the control head cover.

Fire Damper System

Visually inspect the damper or damage and verify that the fusible link is in place between the two couplers as shown in Illustration M.

DANGER

To avoid causing death or serious bodily harm to building occupants, make sure all damper corners are square and the damper has not been damaged. Do not install any damper which is deformed or damaged.

Note: Maintain the UL approval by ordering a replacement fusible link from Johnson Controls before continuing.

DANGER

To avoid causing death or serious bodily harm to building occupants, never install a fire damper without the proper UL approved fusible link in place.

Use the following fusible link:
For code FOVHN (212° F) use replacement fusible link DMPR-RF002.

After you receive the new fusible link:

1. Place the fusible link on the coupler from the bracket shown in Figure 3-9. Use long needle-nose pliers to hold fusible link in position.

2. Attach a pipe wrench to a convenient location on the jackshaft or use a 1/2" open-end wrench on the end of the drive shaft.
3. Rotate the jackshaft in a clockwise direction until the other coupler post is in position and install the fusible link onto the post.
4. Slowly reduce pressure on the pipe wrench until slack is taken up by the fusible link.

WARNING

The damper must be armed. It is shipped with the safety pin installed.

CAUTION

Do not put hands or fingers into the fire damper. It is spring-loaded and bodily harm could result.

Carbon Filters

The carbon filters are 1-3/4 inches by 11-1/2 inches by 19-1/2 inches. The INSIDER requires the use of two (2) filters. The carbon filters should be replaced every six (6) months.

Electronic Air Cleaner

Maintenance and Washing

When to Wash:

Periodically the dirt collected by your unit must be removed. The frequency of washing will depend on the amount of dirt present in the air in you locality.

The washing frequency best suited for you unit can be determined by examining the dirt collected components at three (3) week intervals. As the dirt begins to collect, you will notice a light film, then a very definite collection will be evident at a later examination. When there is a noticeable build-up of dirt, it is time to wash.

In most areas the collecting cell should be washed about every twelve (12) weeks.

Note: Dirt build-up on the ionizing-collecting cell should not be confused with dirt stains. Dirt stains are normal and do not affect efficiency.

Steps for Washing:

1. Switch control switch "OFF".
2. Remove pre-filter and cell.
3. Place components in automatic dishwasher, stationary tub, shower stall or over floor drain. Use hot soapy water and rinse thoroughly. As an aid to drying, rinse with clear, hot water. Allow components to dry thoroughly.

Note: Ionized wires are easily broken. Handle the cells with care.

4. Replace pre-filter and cell.
5. Close cell access door.
6. Switch control switch to "ON".0

If arcing noise occurs due to wet cells, turn switch off and allow more drying time.

If there are any problems, refer to the service checklist.

Troubleshooting

Troubleshooting

This section is designed as an aid in troubleshooting, not as a substitute for a qualified technician. Feel free to call Belshaw Bros. at (206) 322-5474. One of our customer support representatives will be happy to help you. When you call, please specify the following:

- The model name of the machine
- The serial number of the machine
- The voltage, phase, and the hertz (cycles) of the machine.

CAUTION

If you perform repairs yourself or have them performed by anyone other than Belshaw Bros. or a service technician authorized by Belshaw Bros., you do so at your own risk.

For factory service, return your machine, freight prepaid, with your instructions for service, your phone number, and the name of the person for us to contact when we have made a cost estimate. In most cases, the machine can be shipped back, freight collect, within five (5) days.

Ship machines in need of service to:

Belshaw Bros., Inc.
814 44th Street NW, Suite 103
Auburn, WA 98001 USA

Following is a troubleshooting chart to help you identify and solve some basic problems.

WARNING

Disconnect the machine from the power source before disassembling, repairing, or wiring.

1 INSIDER WILL NOT RUN

Possible Cause	What To Do
The power cord is not plugged in, or the outlet has no power.	Connect the machine to a good power source.
The power cord is defective	Replace the power cord.
The circuit breaker has been tripped	Reset it by lifting cover on electrical enclosure and turn Insider breaker to "OFF" and then to "ON".
There is a loose connection	See if circuit breaker has been tripped. Test circuits and repair it.

WARNING

To avoid electrical shock injuries, before doing any of the following, unplug the machine.

2 INSIDER WILL NOT STAY RUNNING

Possible Cause	What To Do
Fuse has blown out	Check fuses located inside electrical enclosure and replace. If condition continues look for electrical short.
Fire suppression system has fired	Call the Pyro-Chem certified personnel to reset & change the system. The interlock switch in the control head will prevent the Insider from running.
Hood doors are not closed or making contact with interlock switches	Close the doors and latch tight or adjust interlock switch position.
Grease baffle filter not installed or properly seated on interlock switch.	Install filter or adjust interlock switch at the bottom of filter opening.
Pre-filter not installed or locked in place	Install filter and lock into place with slide bolts.
Electronic Air Cleaner (air cleaner cell) not installed or locked in place.	Install cell and lock into place with slide bolt. Push the cell all the way back against rear stop and engage slide bolt into hole in sheet metal baffle.

2 INSIDER WILL NOT STAY RUNNING - continued

Possible Cause	What To Do
Carbon Filter not installed or contacting interlock disc.	Install two (2) carbon filters in the slide tray. Make sure that they contact the interlock disc behind the filters. The door pushed the filters back against the disc when it is latched. The disc can be adjusted in or out by turning the disc. If the disc is too loose put Loctite on the threads. The interlock switch can be adjusted from inside the electrical enclosure.
Air pressure differential switch not adjusted properly or obstruction in filters/air flow.	<ol style="list-style-type: none"> 1. Hold the "Start button" in for a few seconds to attain proper air flow. 2. Check, clean or replace filters. 3. Check to see if reed switch is stuck. Tap on switch housing. 4. Check differential adjustment screw located under pressure switch cover, inside upper electrical enclosure. Approximate setting is 2-1/2 turns clockwise with N.O. contacts.
Cell relay interlock is not latching in.	<ol style="list-style-type: none"> 1. Hold the "Start button" in for a few seconds to allow for latching time. 2. Check fuse labeled filter and replace. 3. Check for loose connections and power to relay. 4. Replace relay.
The fire damper is closed	The damper fusible-link has activated the damper. Replace the fusible-link and reset the damper. Temperatures over 212° F will release the damper. Also old or damaged fuse-links may allow damper to close.

3 ELECTRONIC AIR CLEANER – TROUBLECHART

Condition or Symptom	Trouble Description	Probable Location	Possible Cause	Correction
Power On/Off Light (Amber) out	Open Primary Circuit	Primary Wiring	No power from service connection to power supply.	Obtain power
		On/Off Switch	Loose wiring Defective wiring	Repair Replace
Cracking Noise	Objectionable Noise	Cell	Loose Ionizing wire Dirty cell Damaged (bent) plates Damaged (bent) ionizer	Replace Wash Straighten or replace Straighten or replace
Loud Hissing Noise	Same	Cell Hi-Voltage Connection	Dirty Cell Loose Hi-Voltage Connection Insufficient ground	Wash Correct Correct
Radio and/or TV interference	Same	Cell Hi-Voltage Connection	Improper ground Loose Hi-Voltage Connection	Correct Correct
Odor of Ozone	Same		See Page 25	

4 Electronic Air Cleaner Symptoms and Corrections

1. Arcing Noise

When an arcing noise is noted, it is usually located in the DC high voltage circuit. The ionizing-collecting cell is part of this circuit and normally the trouble will be found to be in the cell. The noise is caused by high voltage arcing to ground.

An occasional arcing noise is normal and inherent in all precipitators. These occasional arcs are caused by large particles of dirt in the air such as a cigarette ash, insect, etc. Constant or repeated intermittent arcing should be checked.

Check for:

Loose ionizing wire(s) – repair or replace.

Excessively dirty cell components – clean.

Damaged (bent) plates of ionizer – straighten or replace.

Defective or loose high voltage lead or contact assembly – repair, or replace.

Cracked insulator – replace.

Improper ground – check ground and correct if necessary.

2. Hissing Noise

A hissing noise (or frying sound) usually stems from a loose high voltage connection or from an improper ground. The reduction in the designed spacing usually is caused by bends or deformities in the cell from mishandling.

Check for:

Damaged (bent) plates or ionizer – straighten or replace.

Loose ionizing wires – repair or replace.

Dirty cell or large piece of foreign material between plates. – clean.

Defective high voltage contact assembly – repair or replace.

Poor connection between cell and contact assembly. – repair or replace.

Loose high voltage wiring – repair.

Improper ground – check ground and correct if necessary.

3. Humming Noise

The ionizing wires have a normal tendency to vibrate when charged. On some occasions when atmospheric conditions are just right and the humidity is exceptionally low, the vibration is aggravated to the point where an audible hum can be noted. It is usually noted more in the northern sections of the country during the winter months. This condition can be further aggravated if the ionizing-collecting cell is very dirty. The condition is self-correcting when the relative humidity is increased or can be alleviated by washing the cell.

Radio and/or Television Interference

This trouble is not common but when occurring is usually due to either a continuous high voltage “leak or discharge”, or from the absence of a good common electrical ground. Refer to checks listed under 1. Arcing Noise and 2. Hissing Noise.

4. Ozone

Under normal operating conditions all electrostatic air cleaners produce minute quantities of ozone as an incidental by-product, as do televisions and other electrical appliances. The design of the unit has been tested and is far below the published permissible limits. The level of detection (when it is noticed) varies from individual to individual, some being more susceptible than others. Usually a new unit will produce more ozone than one that has been in operation for several weeks. This is due to the normal amount of sharp corners or manufacturing burrs on the ionizing-collecting cell. The voltage working on these areas however, tends to round them off, thereby they are self-correcting.

An ionizing-collecting cell that has been damaged, where the designed spacing between electrically charged and ground components has been decreased, may also produce an abnormal amount of ozone.

Check for:

- a. Damaged (bent) plates – straighten or replace.
- b. Loose ionizing wires – repair or replace
- c. Dirty cell – clean
- d. Loose high voltage connections – repair or replace.

5 Electronic Air Cleaner **Electrical Problems**

The following instructions are for use by qualified personnel.

WARNING
The following procedures will expose hazardous live parts. Disconnect power before proceeding.

Tools required:

- Two (2) screwdrivers. 8" blade type with insulated handle.
- Needle nose pliers
- Volt/Ohm meter (if available)
- High voltage meter to 10,000 volts DC plus (if available).

These are two areas in which the majority of service problems originate:

- The ionizing-collecting cell
- The power supply

Electrical Trouble

CAUTION

Exercise usual precautions when working with high voltage. When circuit has been de-energized always discharge any residual current in the secondary with an insulated handle screwdriver. Always ground power supply and ionizing-collecting cell when bench testing.

Ionizing-Collecting Cell

The cell is electrically energized through a contact terminal located at the top center of the cell. The ionizing wires and every other collector plate are electrically charged while each interleaving plate is ground. Most trouble in the cell can be readily detected visually.

Power Supply Check (without high volt meter)

Problem Areas	Corrections
Excessive dirt build up	Wash
Large pieces of foreign matter lodged between plates	Remove
Very dirty insulators.	Clean
Broken ionizing wires	Remove all pieces of broken wires and replace
Excessively bent or misaligned components due to mishandling	Straighten or replace
Externally broken or cracked insulators	Replace

System Check

A simple system check can be made by drawing an arc as follows:

Remove pre-filter and cell.

Remove pre-filter from cell.

Re-install cell without pre-filter.

Use screwdriver to energize safety switch. If high volt meter is not available proceed as follows:

Use an insulated screwdriver to draw an arc between extended ground plate and ionizing wire. A sharp electrical arc of approximately 1/4" should be observed. This indicated proper cell operation. If weak arc or no arc is observed, follow cell and power supply checkout.

If using high volt meter, voltage should read between 5.9 – 6.5 kilovolts. If voltage is below 6 kilovolts or no output at all, the problem lies in either the cells or power supply. See Electronic Air Cleaner - Troublechart, page 24.

If there is primary power to the power supply and the secondary output voltage is absent or very low, the power supply is defective. Drawing an arc, with an insulated handle screwdriver between common ground and the high voltage output terminal (c) can make a simple check. A good power supply will produce a pronounced arc where a defective one will produce no arc at all or a very weak one.

(Refer to illustration “N” Trouble shooting Trion-power supply).

Power Supply Check (with DC high volt meter).

Take reading with the high voltage meter at cell contact point. Voltage should read 7 kilovolts or higher (without cell connected). If voltage is above 7 kilovolts, the problem is in the cell (see cell checkout procedure). If voltage is below 7 kilovolts (without cell connected), the problem is in the power supply.

Proceed as follows:

Remove power pack from the unit.

Check for loose wires; if loose wire found, reconnect.

If defective power supply is indicated, replace.

4 TROUBLE SHOOTING
TRION-POWER SUPPLY
ILLUSTRATION N

HIGH FREQUENCY
POWER SUPPLY
PART NO. 347155-XXX

THE FOLLOWING ARE APPROXIMATE
RESISTANCE VALUES ±20%

TEST POINTS (A) TO (B)	RESISTANCE 70 OHMS FOR 120 VAC RATED UNIT 33 OHMS FOR 100 VAC RATED UNIT 300 OHMS FOR 220 AND/OR 240 VAC RATED UNIT 150 MEG OHMS
(D) TO (C)	

THE FOLLOWING ARE APPROXIMATE OUTPUT
VOLTAGE AT RATED INPUT VOLTAGE

TEST POINTS (D) TO (C)	SECONDARY AC VOLTAGE 6200 VAC=300V (WITH CELL CONNECTED) 300 OHMS FOR 220 AND/OR 240 VAC RATED UNIT 7000 VAC MIN (WITH CELL DISCONNECTED)
(D) TO (C)	

POWER SUPPLY TEST

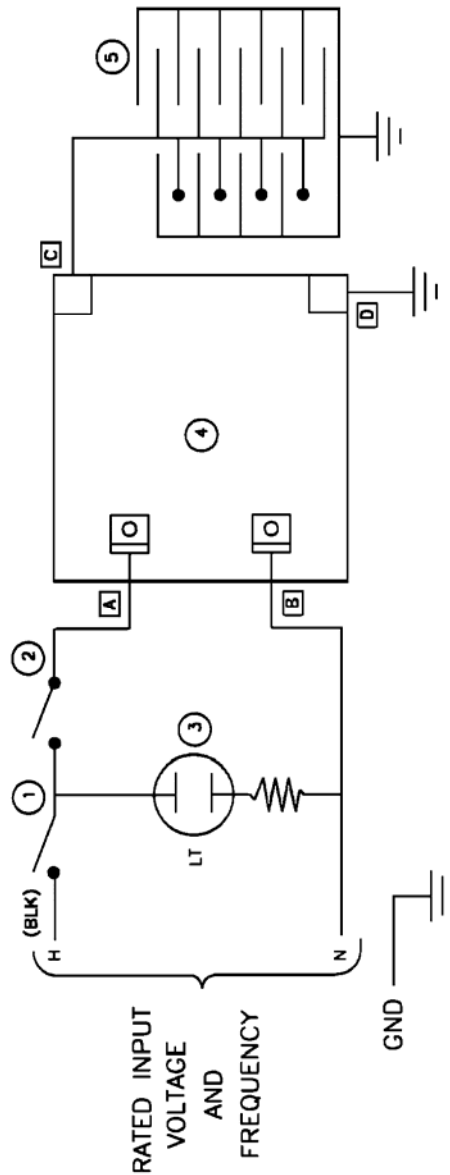

KEY

1. ON-OFF SWITCH
2. SAFETY INTERLOCK SWITCH
3. POWER INDICATING LIGHT
4. HIGH FREQUENCY POWER SUPPLY
5. IONIZING-COLLECTING CELL

OUTPUT: THIS IS A HIGH FREQUENCY SOLID STATE CIRCUIT DESIGNED
FOR ELECTRONIC AIR CLEANERS WITH HIGH PERFORMANCE RELIABILITY.

- 900 MICRO AMPS
- 6.2 ±.3 KVDC (WITH CELL CONNECTED)
- 7 KVDC MIN. (WITHOUT CELL CONNECTED)

WARNING WHEN BENCH TESTING POWER SUPPLY
ALWAYS ATTACH GROUND WIRE.

In this section, please find information relating to Pyro-Chem and Kitchen Knight Fire Suppression System.

- In Case of Fire
- Pyro-Chem Contacts
- Kitchen Knight II Owner's Manual for PCL-300/460/600
- Pyro-Chem Kitchen Knight II General Information
- Pyro-Chem Kitchen Knight II Components
- Pyro-Chem Kitchen Knight II Maintenance

In Case of Fire

Fires can potentially start in a cooking appliance, the hood, or the duct. In case of fire, it is important that you fully understand the operation of your fire suppression system.

1. Evacuate all personnel and customers from the fire area.
2. If your fire control system has not already automatically activated, you may activate it manually by pulling the handle on the silver manual pull station, located at the back of the Insider to the right of the red fire extinguisher cylinder.
3. Call the fire department.
4. Personnel trained in the proper operation of hand portable extinguishers may stand by if means of easy exit are available.

When the fire has been extinguished, call your authorized Pyro-Chem distributor to recharge the system, after determining the cause of fire. Under no circumstance should cooking operations be attempted before qualified personnel re-instate the integrity of your fire suppression system.

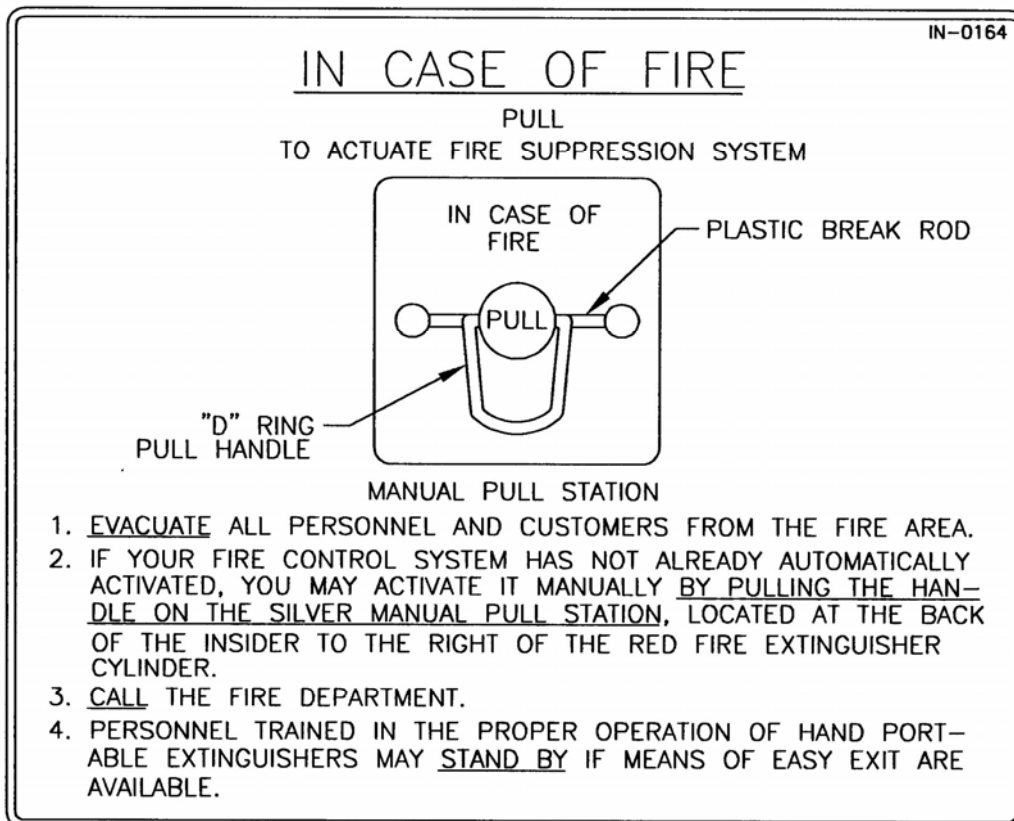

To schedule a kitchen style fire suppression test:

United States

Call Pyro-Chem at 1-800-526-1079

Or visit their website at www.pyrochem.com and click on "Key Contacts" to find the Sales Representative for your region.

5

Appendix

Pyro Chem Kitchen Knight Manual

Parts List Drawing Insert Page



Belshaw Bros., Inc • 814 44th Street NW, Suite 103 • Auburn, WA 98001 • USA
Tel: 206-322-5474 • Fax: 206-322-5425 • www.belshaw.com

INFORMATION FOR CUSTOMERS AND APPROVAL AUTHORITIES

INSIDER DONUT FRYING SYSTEM

**COMMERCIAL ELECTRIC COOKING APPLIANCE
WITH INTEGRAL RECIRCULATING SYSTEM**

INSTALLATION REQUIREMENTS

- **INSIDER FLYER**
- **SPECIFICATION SHEET**
- **FIRE SUPPRESSION DESCRIPTION**
- **INSTALLATION INFORMATION**
- **STANDARDS & LISTINGS – ETL/UL/NFPA**
- **ETL/UL LABELS**
- **PYRO-CHEM DATA SHEET**

**COMPLETE INSTALLATION PROCEDURES ARE LISTED IN THE
INSIDER INSTALLATION, OPERATORS AND MAINTENANCE MANUAL**



Belshaw Bros., Inc • 814 44th Street NW, Suite 103 • Auburn, WA 98001 • USA
Tel: 206-322-5474 • Fax: 206-322-5425 • www.belshaw.com

Insider™

The Belshaw's Insider™ (Donut Frying System) comprehensively addresses all fire prevention, clean air, sanitation and electrical requirements and the self-contained unit meets or exceeds local standards. The Insider houses one of the following Donut Robot Fryers; MKII, MKV or MKIX and is UL197 Listed under ETL #68183.

- Tested to UL197 standards for Commercial Electric Cooking Appliances with Recirculating Systems and Listed under ETL #68183.
- Intended for installation and use to NFPA-96 Standard For Ventilation Control and Fire Protection of Commercial Cooking Operations.

Fire Prevention/ Suppression System

The Insider™ uses the Pyro-Chem Restaurant Fire Suppression System. It is a pre-engineered type as defined by NFPA-17A Standard for Wet Chemical Extinguishing Systems and is designed to provide fire protection for restaurant cooking appliances, hoods, and ducts.

The Pyro-Chem System (PLC-240/300 KITCHEN KNIGHT II) utilizes a wet chemical agent specifically designed to suppress restaurant-cooking fires. The system provides automatic actuation and can be manually actuated through a remote mechanical pull station. Upon actuation, the system discharges a pre-determined amount of agent to the duct, plenum, and cooking appliances. The agent acts to suppress fires in 3 ways:

- Both the agent itself and the resulting steam formation interrupt the chemical chain reaction causing combustion.
- The agent cools the fire bringing it below auto-ignition temperature.
- The agent reacts with hot grease forming a soap-like layer (saponification) that helps prevent the escape of combustible vapors, thus preventing re-ignition.

The Pyro-Chem Restaurant Fire Suppression System has been tested to the UL Standard for Fire Extinguishing Systems For Protection of Restaurant Cooking Areas, UL300 and Pyro-Chem listed by Underwriters Laboratories, Inc. under ULC/ORD-C1254.6-1995 listing meets Underwriters Laboratories of Canada's standards.

Clean Air- Ozone and Emissions

The Insider™ meets the emission requirements of 5.0mg/m³ as measured at the exhaust outlet of the system per the requirements of the U.S. Environmental Protection Agency (EPA) Test Method 202, Determination of Condensable Particulate Emissions from Stationary Sources, which is referenced in NFPA-96 (Test results 1.81 mg/m³) UL File E213302.

Underwriters Laboratories also tested it at well below the maximum ozone levels permitted of 0.1ppm time-weighted average with a maximum peak concentration of 0.3ppm (Test results less than 0.015 ppm).

Sanitation

The Insider™ is built in accordance with NSF International Standard No. 4, for commercial cooking and hot food storage equipment and conforms to ANSI/NSF STD 4 (ETL Listing #68183).

The fryer portion, Donut Robot Mark II, Mark V, or the Mark IX, is separately ETL Classified in accordance with NSF International Standard No. 4. One of the above models is used in each Insider™:

Materials employed have been found to be able to withstand normal wear, penetration of vermin, corrosive action of foods, cleaning products, and other elements in the end use environment. The materials do not impart an odor, color, taste, or toxic material to food products.

Electrical

The Insider™ and the Mark Donut Robots are also listed as Commercial Cooking Appliances, in accordance with UL 197, and they are in compliance with electrical code ANSI/NFPA 70 the Standard for Commercial Electric Cooking Appliances and conforms to ANSI/UL STD 197 Certified to CAN/CSA C22.2 STD No. 109 (ETL Listing #68183).



Belshaw Bros., Inc • 814 44th Street NW, Suite 103 • Auburn, WA 98001 • USA
Tel: 206-322-5474 • Fax: 206-322-5425 • www.belshaw.com

Insider Installation Requirements

INSTALLATION must be done by **certified personnel** acceptable to the **authority having jurisdiction** and they shall inspect and test the Insider. A test of the safety interlocks, control head and manual pull station may be performed and a **trip test** and **dry pressure test** may also be required at installation.

The charging and setup of the Pyro-Chem PLC-240/300 **Fire Suppression System** must be done by certified personnel and the use and maintenance of the Insider is to be in accordance with **NFPA-96**.

The manufacturer's instructions for "**System Checkout after Installation**" is on page 17 of the Insider Installation, Operators and Maintenance Manual.

After testing, the Fire Suppression System will need to be activated by screwing the carbon dioxide pilot cartridge into the actuator, removing the control head safety pull pin, replacing the control head cover and removing the Fire Damper Safety Pin.

A signed and dated log of installation and maintenance must be kept on premises for use by authority having jurisdiction.

ETL/UL/NFPA - STANDARDS AND LISTINGS

- UL197SB/UL710B (KNKG7) - Standard for Commercial Electrical Cooking Appliances with Integral Recirculating Systems and Listed under ETL #68183, Conforms to ANSI/UL STD 197, certified to CAN/CSA C22.2 STD No. 109
- NSF 4 –Commercial Cooking, Rethermalization and Powered Hot Food Holding and Transport Equipment and Listed under ETL #68183, conforms to ANSI/NSF4-2002e.
- NFPA-96 - used in accordance with Standard For Ventilation Control and Fire Protection of Commercial Cooking Operations.
- NFPA-17A - the Insider uses the pre-engineered Pyro-Chem Restaurant Fire Suppression System (PLC-240/300 Kitchen Knight II).

ETL/UL/NFPA cont.

- UL300 - Standard For Fire Extinguishing Systems For Protection of Restaurant Cooking Areas and Pyro-Chem Listed under ULC/ORD-C1254.6-1995.
- ANSI/NFPA 70 - Electrical Code – used in accordance with Standard for Commercial Electric Cooking Appliances.

LOCAL PERMITS and approval by the **Fire Marshal** may be required. The Insider is a UL Listed portable plug in appliance (single) and is not a fixture. It is a **portable appliance** for use in noncombustible surroundings.

MODIFICATIONS AND CHANGES will invalidate the ETL Listing of this appliance. The Insider has been fire tested by UL/ETL, as a stand-alone appliance, and is not subject to change. The ETL Listing does not allow it to be hardwired or permanently attached to the building structure. The Remote Manual Pull Station must remain on the Insider as UL/ETL Listed and Tested. The Fire Suppression System shuts down all electrical circuits during a fire. An auxiliary circuit or permanent connection to the building alarm system is not a part of this ETL Listing.



Belshaw Bros., Inc • 814 44th Street NW, Suite 103 • Auburn, WA 98001 • USA
Tel: 206-322-5474 • Fax: 206-322-5425 • www.belshaw.com

Insider Certification Labels



MAINTENANCE

READ AND UNDERSTAND THE OWNERS MANUAL FOR THIS FIRE SUPPRESSION SYSTEM. THE EXTINGUISHING SYSTEM UNIT SHALL BE INSPECTED MONTHLY, OR AT MORE FREQUENT INTERVALS WHEN CIRCUMSTANCES REQUIRE. RECHARGE IF PRESSURE IS BELOW OPERABLE RANGE. THE UNIT SHALL BE PRESSURIZED AS INTENDED. CHECK TO MAKE SURE THE TAMPER SEAL IS INTACT. THE PIPING AND NOZZLES SHOULD BE EXAMINED TO ASCERTAIN THAT THEY ARE UNOBSTRUCTED. INSTALL, INSPECT, MAINTAIN AND TEST IN ACCORDANCE WITH PYRO-CHEM MANUAL P/N 561738 AND NFPA 17A STANDARD FOR WET CHEMICAL EXTINGUISHING SYSTEMS.

RECHARGE

CYLINDER MUST BE RELIEVED OF REMAINING PRESSURE BEFORE REMOVING VALVE ASSEMBLY. THE RECHARGE PROCEDURE MUST BE DONE BY A QUALIFIED PYRO-CHEM DISTRIBUTOR IN ACCORDANCE WITH THE APPROVED PROCEDURES ESTABLISHED BY PYRO-CHEM. REFILL ONLY WITH 2.4 GAL (9.06 L) OF PYRO-CHEM WET AGENT P/N 561738 AND PRESSURIZE TO 175 PSI (12.06 BAR) AT 70 °F (21 °C). APPROXIMATE GROSS WEIGHT 47 LBS. (21.3 KG) (CYLINDER, AGENT AND VALVE).



**KITCHEN
KNIGHT II™**

RESTAURANT FIRE SUPPRESSION SYSTEM

PCL-300

**THIS SYSTEM IS INTENDED
FOR INDOOR USE ONLY**

**MEETS THE REQUIREMENTS
OF STANDARD UL300**



LISTED 1656

Wet Chemical Solution
Extinguishing System Unit
PRE-ENGINEERED TYPE

ACCEPTED BY MATERIAL &
EQUIPMENT ACCEPTANCE
DIVISION OF THE CITY OF NEW
YORK MEA91-99-E
VOL. II

WARNING
THE ANTI-RECOIL PLUG SHALL BE INSTALLED ON THE CYLINDER VALVE EXCEPT WHEN THE CYLINDER ASSEMBLY IS CONNECTED TO THE SYSTEM PIPING OR WHEN THE CYLINDER IS BEING FILLED.

CAUTION

- CONTENTS UNDER PRESSURE 175 PSI (12.06 BAR) OPERATING PRESSURE AT 70 °F (20 °C)
- RECHARGE CYLINDER IMMEDIATELY AFTER USE
- DO NOT EXPOSE TO TEMPERATURES EXCEEDING 120 °F OR (49 °C). OPERABLE RANGE OF SYSTEM IS 32 °F TO 120 °F (0 °C TO 49 °C).
- CYLINDER FACTORY TEST PRESSURE 450 PSI (31 BAR). CYLINDER MEETS DOT REQUIREMENTS.
- IF CYLINDER SHOWS SIGNS OF CORROSION OR MECHANICAL DAMAGE IT MUST BE HYDROSTATICALLY TESTED IN ACCORDANCE WITH NFPA 17A, OR IT MUST BE REPLACED.

ASSEMBLY P/N 551194

HMIS
WET SOLUTION AGENT HM2S 2.0-DPOTASSIUM CARBONATE/ALKALINE PHTANT, NITROGEN EXPELLANT GAS HM15 0.0-VERY LOW DISCHARGE. CONTENTS UNDER HIGH PRESSURE.

MSDS AVAILABLE AT:

www.pyrochem.com

**THE DATE OF MANUFACTURE IS
ON THE CYLINDER**



ONE STANTON STREET
MARNETTE, WI 54143-2542
715-732-3465