



BEVERAGE-AIR

3779 Champion Blvd., Winston-Salem, NC 27105
1-888-845-9800 Fax# 1-336-245-6453
<http://www.Beverage-Air.com>

Commercial Refrigeration Equipment General Specification

3 Year Parts/Labor Warranty Additional 2 Year Compressor Warranty

CABINET CONSTRUCTION

- Exterior—Stainless steel interior and exterior standard.
- Insulation—foamed-in-place CFC and HCFC-free polyurethane insulation.
- One-piece grille allows easy removal/installation for preventative maintenance.

OPTIONAL WHITE OR BLACK INTERIOR/EXTERIOR FINISHES

ELECTRONIC CONTROL

- Electronic thermostat with manual defrost button provides a digital display of cabinet temperatures, which includes status indicators and key pad for any necessary temperature adjustments.

AUDIBLE/VISUAL ALARM STANDARD

OPTIONAL SAFETEMP ELECTRONIC CONTROL with automatic door locking mechanism when temperatures exceed product safety zone.

OPTIONAL ETHERNET CONTROL SERVER for temperature and monitoring notification.

OPTIONAL LED LIGHTING

REFRIGERATION SYSTEM

- Whisper-Quiet refrigeration with noise level of less than 65 decibels.
- Bottom mount balanced refrigeration system for better ergonomics.
- Automatic condensate evaporation system for energy efficiency.
- Forced-air system ensures uniform distribution of airflow throughout the entire cabinet to ensure even product temperatures. Solid door models are designed to maintain 0°F at 100°F ambient according to NSF7; Glass door models are designed for -10°F at 86°F ambient and -15°F at 75°F ambient.
- Self-contained refrigeration system uses environmentally friendly (CFC and HCFC-free) R404A refrigerant.
- Defrost system is automatic, time-initiated and temperature terminated operation.

DOORS

- Choose from full solid door or full glass door configurations.
- **Glass door units only:** Highly efficient triple pane glass. Glass is heated to prevent any condensation formation. Inside and outside panes are tempered for added safety.
- Anti-microbial door handles and door locks are standard.
- Spring-loaded hinges standard. Positive seal self-closing door(s) with 120° stay open feature.
- Plug-in magnetic door gaskets of one piece construction, removable without tools for ease of cleaning.

SHELVING

- Eight (8) heavy duty epoxy coated wire shelves per door section standard. Four (4) shelf clips included per shelf (field installed).
- Shelves are adjustable in ½" increments.

HORIZON SERIES WHISPER-QUIET PHARMACY FREEZERS

Solid Doors and Glass Doors

MODEL:
HBF23-1-AVA / HBF23-1-G-AVA
HBF27-1-AVA / HBF27-1-G-AVA
HBF49-1-AVA / HBF49-1-G-AVA
HBF72-1-AVA / HBF72-5-G-AVA

PHARMACY FREEZERS



HBF23-1-AVA
(SHOWN WITH FULL SOLID DOOR)
Full Glass Door model available



HBF27-1-AVA
(SHOWN WITH FULL SOLID DOOR)
Full Glass Door model available



HBF49-1-AVA
(SHOWN WITH FULL SOLID DOOR)
Full Glass Door model available

MODEL FEATURES

- Incandescent interior lighting—*solid door units*. Fluorescent interior lighting—*glass door units*.
- **LED lighting option**—*glass door units only*.
- 6" heavy-duty casters included, two with brakes standard. 3" casters or 6" legs optional.
- Pre-wired plug for 115/60/1 phase.
HBF72-5-G powered by 115/208-230 volts is designed for field wiring (requires 4-wire electrical circuit, hard-wired).
- Epoxy coated evaporator prevents corrosion.
- ENERGY STAR® Qualified
- UL-EPH and CUL for open food product.

Available From:



*Note: Not all markings may apply to all model variations.

Model Specified _____	Store# _____
Location _____	Quantity _____



Horizon Series Pharmacy Freezers

Models: HBF23, HBF27, HBF49, HBF72

MODEL	HBF23	HBF27	HBF49	HBF72	HBF72 GLASS DOOR
EXTERNAL DIMENSIONAL DATA					
Length Overall (inches)	27 1/4"	30"	52"	75"	75"
Length Overall (mm)	692	762	1321	1905	1905
Depth Overall (inches) - includes handle	33 3/4"	33 3/4"	33 3/4"	33 3/4"	33 3/4"
Depth Overall (mm) - includes handle	857	857	857	857	857
Height Overall—(inches) / (mm) <i>Add 6" for legs or casters</i>	78" / 1981	78" / 1981	78" / 1981	78" / 1981	78" / 1981
Number of doors	1	1	2	3	3
Depth with Door Open 90 °	60"	60"	60"	60"	60"
INTERNAL DIMENSIONAL DATA					
NET Capacity (cubic ft.)	23	27	49	72	72
NET Capacity (Liters)	651	765	1388	2039	2039
Internal Length Overall (inches)	24"	27"	49"	72"	72"
Internal Length Overall (mm)	610	686	1245	1829	1829
Internal Depth Overall (inches)	28 1/2"	28 1/2"	28 1/2"	28 1/2"	28 1/2"
Internal Depth Overall (mm)	724	724	724	724	724
Internal Height Overall—(inches)	61 3/4"	61 3/4"	61 3/4"	61 3/4"	61 3/4"
Internal Height Overall—(mm)	1569	1569	1569	1569	1569
Number of shelves	8	8	16	24	24
ELECTRICAL DATA					
Full Load Amperes 115/60/1	10.9 A	11.9 A	11.9 A	11.9 A	15 A / 208-230v*
REFRIGERATION DATA					
Horsepower	1/2	3/4	3/4	3/4	2 @ 1/2
WEIGHT DATA					
Gross Weight (Crated lbs) Solid / Glass	300 / 325	373 / 400	530 / 560	715	775
Gross Weight (Crated kg) Solid / Glass	136 / 147	169 / 181	240 / 254	324	352

PLAN VIEWS

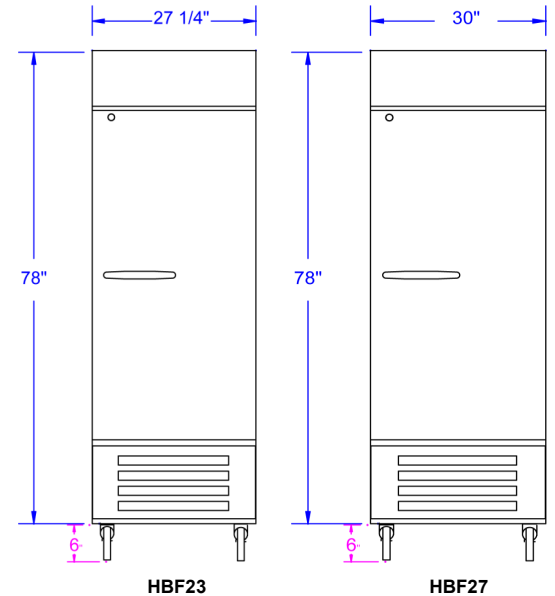

*Note: Freezers powered by 115/208-230 volts are designed for field wiring (requires 4-wire electrical circuit, hard-wired).
 Note: Not all markings may apply to all model variations.

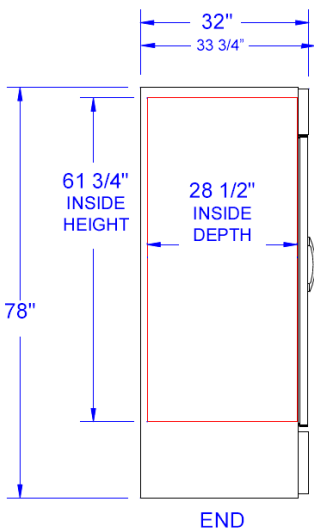

END
COMMON END

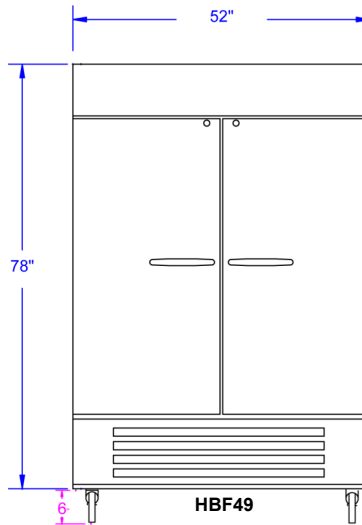

HBF49

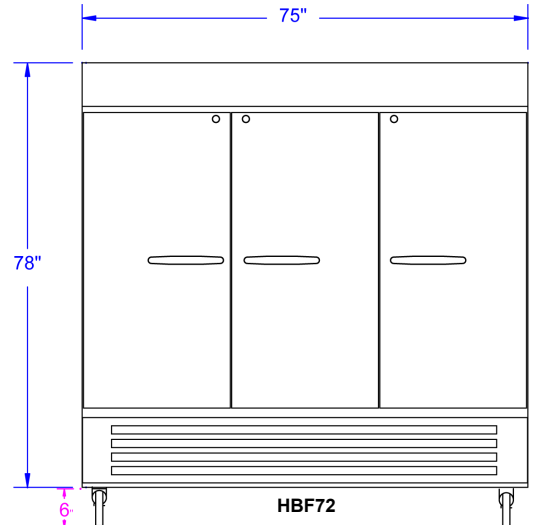

HBF72

BEVERAGE-AIR® CORPORATION

3779 Champion Blvd. • Winston-Salem, NC 27105 USA • (336) 245-6400 • Fax (336) 245-6453 • (888) 845-9800 • www.beverage-air.com

Specifications are subject to change without prior notice. 03/13